

MINDEO

MS3690 Lightweight Data Terminal User Manual



Version: MS3690_UM_EN_V1.0.9

Notice

MS3690 is a lightweight programmable data terminal. A SDK based on C is provided including user-friendly IDE and fully functional APIs.

Before operating the terminal, please make sure you carefully read the following information to ensure that your terminal is able to perform at the level for which it is designed.

1. All software, including firmware, furnished to the user is on a licensed basis.
2. The right is reserved to make changes to any software or product to improve reliability, function, or design.
3. The contents of this manual are subject to change without notice.
4. The manufacturer assumes no responsibility for any loss or claims by third parties which may arise from the use of this manual.
5. Do not throw or drop the terminal or otherwise subject it to strong impact, which can damage the terminal, interrupt program execution, corrupt memory contents, or otherwise interfere with proper operation.
6. A standard packing includes a terminal, a USB cable and a CD (containing software and electrical manuals). Accessory includes a cradle and an AC/DC adaptor for battery charge.
7. **Please charge the battery before the first time of use.**
8. The term “terminal” as used in this manual denotes the MS3690 terminal unless otherwise noted.

Contents

Notice	ii
Contents	iii
1 Specifications	1
1-1 Technical specifications.....	1
1-2 Default settings for each barcode.....	3
1-3 Dimensions.....	4
1-4 Parts of the terminal.....	5
1-5 Introduction of keys.....	6
1-6 Parts of the cradle.....	7
2 Introduction of installation	8
2-1 Installing a USB HID keyboard wired terminal.....	8
2-2 Installing a USB virtual COM wired terminal.....	8
2-3 Replacing the Lithium-ion battery.....	9
3 Getting started	10
3-1 Power on/off terminal.....	10
3-2 Charge terminal.....	10
3-3 Enter/Exit sleep mode.....	10
3-4 Power on/off Bluetooth.....	10
3-5 Power on/off Wi-Fi.....	11
4 Introduction of OLED display	12
4-1 OLED display icons.....	12
4-2 OLED display menu.....	13
5 Operations of the terminal	17
5-1 Scan.....	17
5-1-1 Scan Mode.....	17
5-1-2 Input Data Manually.....	18
5-1-3 Quantity Enter.....	18
5-1-4 Add Time/Date.....	18
5-1-5 Set Separator.....	19
5-1-6 Database Function.....	19
5-1-7 Sum Total.....	20
5-1-8 Transfer Confirm.....	20
5-2 Data Transfer.....	20
5-2-1 Bluetooth.....	20
5-2-2 Wi-Fi.....	21
5-2-3 USB HID Keyboard.....	21
5-2-4 USB Virtual COM.....	21

5-2-5 U Disk	21
5-2-6 Data batch	22
5-3 System Setting	23
5-3-1 Bluetooth Functionalities	23
5-3-2 Wi-Fi	25
5-3-3 USB HID Keyboard	29
5-3-4 Language	29
5-3-5 Character Encoding	29
5-3-6 Sound	30
5-3-7 Vibration	30
5-3-8 Screen	30
5-3-9 Sleep	30
5-3-10 Time and Date	30
5-3-11 Default Setting	30
5-4 System Information	31
5-4-1 View Memory	31
5-4-2 Bluetooth	31
5-4-3 Wi-Fi	31
5-4-4 Firmware Version	31
6 User customized application software for MS3690	32
6-1 Auto Run	32
6-2 Execute	32
6-3 Download	32
7 Barcode programming instructions	33
7-1 Example: Setting parameter	33
7-2 Decode illumination and decode aiming pattern	34
7-3 Other setting	35
7-4 Scanning mode and some global settings	36
7-5 UPC-A	39
7-6 UPC-E	41
7-7 UPC-E1	43
7-8 EAN-13 (ISBN/ISSN)	45
7-9 EAN-8	47
7-10 Code 39 (Code 32, Trioptic Code 39)	49
7-11 Interleaved 2 of 5	52
7-12 Industrial 2 of 5 (Discrete 2 of 5)	53
7-13 Matrix 2 of 5	54
7-14 Codabar	55
7-15 Code 128	57

7-16 UCC/EAN 128.....	58
7-17 ISBT 128.....	59
7-18 Code 93.....	60
7-19 Code 11.....	61
7-20 MSI/Plessey.....	63
7-21 UK/Plessey.....	65
7-22 China Post.....	66
7-23 GS1 DataBar (GS1 DataBar Truncated).....	67
7-24 GS1 DataBar Limited.....	68
7-25 GS1 DataBar Expanded.....	69
7-26 PDF417.....	70
7-27 MicroPDF417.....	70
7-28 QR Code.....	70
7-29 MicroQR Code.....	70
7-30 Data Matrix.....	71
7-31 Han Xin Code.....	71
7-32 Aztec Code.....	71
7-33 G1-G4 & C1-C3 & FN1 substitution string setting.....	72
7-34 G1-G4 string position & Code ID position.....	77
7-35 String transmission.....	78
8 Barcode representing non-printable character.....	81
9 ASCII Table.....	82
10 Test Chart.....	83
11 Return default parameters & firmware version.....	86
12 Configuration alphanumeric entry barcode.....	87

1 Specifications

1-1 Technical specifications

Items	MS3690-1D	MS3690-2D
Working range	Bluetooth: 30m(line of sight) Wi-Fi: 100m(line of sight)	
Radio link	Bluetooth: 2.4–2.5GHz, Bluetooth 4.0/3.0/2.1+EDR, Class 2 Wi-Fi : 2.4GHz, compliant with Wi-Fi IEEE 802.11 b/g/n protocol standards	
Interface	Bluetooth: HID keyboard, SPP, BLE Wi-Fi: Station mode(STA), Access Point mode(AP) USB: USB HID keyboard, USB virtual COM, U Disk	
Data storage	4MB for out of range batch: 250,000 barcodes(each barcode is of 15 bytes) 8MB for data batch mode: 500,000 barcodes(each barcode is of 15 bytes) 76MB for U Disk mode: 5,000,000 barcodes(each barcode is of 15 bytes)	
Keyboard layout	USA、Turkish F/Q、French、Italian、Spanish、Slovak、Denmark、Japanese、German	
Dimensions	Length × Width × Depth: 12.5×4.6×3.1cm	
Weight	115g	108.8g
Color	Gray/Black/White/Customization	
Case material	ABS	
Indicator	Beeper、LED、Vibrator	
Display	OLED display(128×64)with LED backlight	
Operating mode	Handheld	
Programming method	Manual(reading special barcode),On-Screen(pressing special keys)	
Firmware upgrade	Online via USB interface	
Input Voltage	4.75V – 5.25V	
Standby current	Bluetooth: 4 mA Wi-Fi: 4 mA	Bluetooth: 0.6 mA Wi-Fi: 0.6 mA
Working current	Bluetooth: 75 mA (Bluetooth On) Wi-Fi: 127 mA (Wi-Fi On)	Bluetooth: 78 mA (Bluetooth On) Wi-Fi: 138 mA (Wi-Fi On)
Scanning current	Bluetooth: 135 mA (Bluetooth On) Wi-Fi: 187 mA (Wi-Fi On)	Bluetooth: 435 mA (Bluetooth On) Wi-Fi: 500 mA (Wi-Fi On)
Battery	1900 mAh Lithium-ion battery	
Charging time	Fully charged(>80%)in 4 hours	
Charge current	500mA	
Standby time	14 days	30 days
Working time	Bluetooth: 22 hours Wi-Fi: 13 hours (based on 1 scan/5 seconds)	Bluetooth: 19 hours Wi-Fi: 12 hours (based on 1 scan/5 seconds)

Illumination LED	650nm visible laser diode	White emitting color, standard: 2700K, optional: 5000K		
Aiming LED	/	617 nm peak wavelength, red LED		
Image size	/	1280×800 pixels		
Scanning angle	/	Horizontal : 41° , vertical : 28°		
Scanning angle	±50° , ±65° , ±35° (Skew, Pitch, Roll)	±70° , ±75° , 360° (Skew, Pitch, Roll)		
Scanning rate	100±10 times/second	/		
Barcode contrast	minimum 20%			
Decode capability	UPC-A , UPC-E , EAN-13 , EAN-8 , ISBN/ISSN , Code 39 , Code 39 full ASCII , Code 32 , Trioptic Code 39 , Interleaved 2 of 5 , Industrial 2 of 5 , Matrix 2 of 5 , Codabar(NW7) , Code 128 , Code 93 , Code 11(USD-8) , MSI/Plessey , UK/Plessey , UCC/EAN 128 , China Post , GS1 DataBar(formerly RSS) variants	1D: UPC-A , UPC-E , EAN-13 , EAN-8 , ISBN/ISSN , Code 39 , Code 39 full ASCII , Code 32 , Trioptic Code 39 , Interleaved 2 of 5 , Industrial 2 of 5 , Matrix 2 of 5 , Codabar(NW7) , Code 128 , Code 93 , Code 11(USD-8) , MSI/Plessey , UK/Plessey , UCC/EAN 128 , China Post , GS1 DataBar(formerly RSS) variants 2D: PDF417 , MicroPDF417 , QR code , Micro QR , DataMatrix , Han Xin Code , Aztec Code		
Scan engine	uE966	ME5600		
Minimum resolution	1D: 4mil	1D: 3mil		
Decoding depth	4mil (9B): 50-90mm 5mil (12B): 50-115mm 10mil (3B): 20-260mm 15mil (3B): 30-380mm 20mil (3B): 45-490mm 30mi l(2B): 40-700mm 55mil (2B): 80-850mm	3mil (3B): 4mil (9B): 10mil (3B): 13mil (6B): 6.7mil (20B): 10mil (20B): 20mil (20B):	HD 43-95mm 35-123mm 21-240mm 17-270mm 24-159mm 17-187mm 20-290mm	SR \ 69-123mm 25-283mm 18-326mm 40-160mm 25-193mm 25-360mm
Temperature	working: -20°C to 55°C(-4°F to 131°F) storage: -40°C to 70°C(-40°F to 158°F)			
Humidity	5% to 95%(non-condensing)			
Safety	Laser safety: EN60825-1 , Class 1 EMC : EN55032 , EN55035 Electrical safety: EN62368-1 Illumination: 0~100,000LUX Protection class: IP65 Drop resistance: Multiple 1.2m(4.9ft)drops to concrete Environmental: RoHS compliant			

*Bluetooth and Wi-Fi are optional (Alternative).

1-2 Default settings for each barcode

Code type	Read enable	Check digit verification	Check digit transmission	Min.code length	Proprietary code ID	AIM code ID
UPC-A	√	√	√	(12) ²	A]Em
UPC-E	√	√	√	(8) ²	D]Em
UPC-E1	-	√	√	(8) ²	D]X0
EAN-13	√	√	√	(13) ²	A]Em
EAN-8	√	√	√	(8) ²	C]E4
ISBN/ISSN ¹ (Bookland EAN)	√	√	√	(13) ²	B]Em
Code 39	√	-	-	1	M]Am
Interleaved 2 of 5	√	-	-	6	I]Im
Industrial 2 of 5	-	-	-	4	H]S0
Matrix 2 of 5	√	-	-	6	X]X0
Codabar	√	-	-	4	N]Fm
Cade 128	√	√	-	1	K]Cm
UCC/EAN 128	√	√	-	1	K]Cm
ISBT 128	√	√	-	1	K]Cm
Code 93	√	√	-	1	L]Gm
Code 11	-	√	-	4	V]H3
MSI/Plessey	-	-	-	4	O]Mm
UK/Plessey	-	√	-	1	U]Mm
China Post	√	-	-	(11) ²	T]Im
GS1 DataBar	√	-	-	(16) ²	R]em
GS1 DataBar Truncated ³	√	-	-	(16) ²	R]em
GS1 DataBar Limited	√	-	-	(16) ²	R]em
GS1 DataBar Expanded	√	-	-	1	R]em
GS1 Composite	-	-	-	-	y]em
PDF417	√	-	-	-	p]Lm
MicroPDF417	-	-	-	-	p]Lm
QR	√	-	-	-	q]Qm
Micro QR	-	-	-	-	q]Qm
DataMatrix	√	-	-	-	d]dm
Han Xin Code	-	-	-	-	h]X0
Code Aztec	-	-	-	-	a]zm

Note: ¹The settings for ISBN/ISSN and EAN-13 must be the same.

² Fixed-length barcodes.

³The settings for GS1 DataBar Truncated and GS1 DataBar must be the same.

1-3 Dimensions

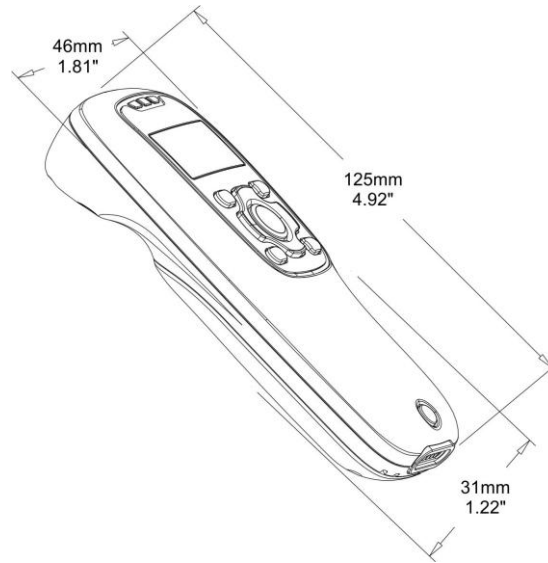

Figure 1-1 Dimensions of the terminal

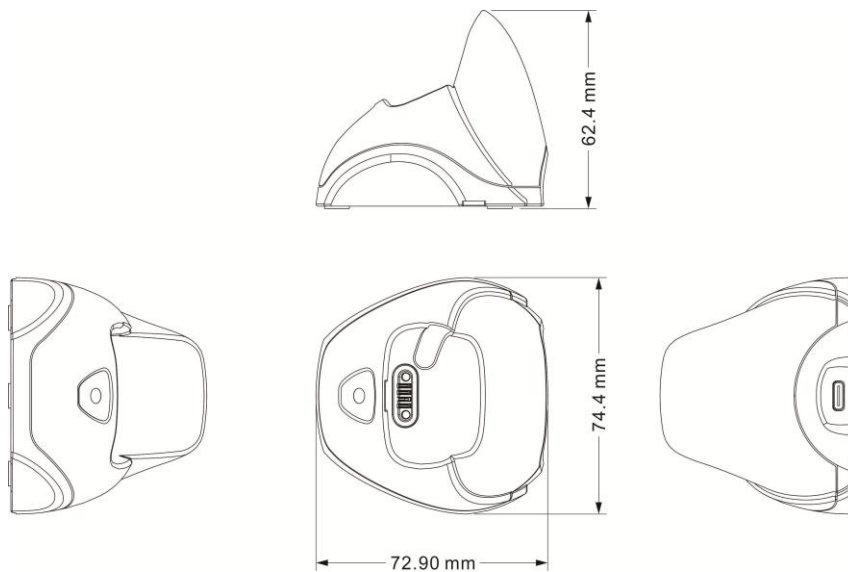

Figure 1-2 Dimensions of the cradle

Note : There are two types of cradle, one is a Bluetooth cradle, which can communicate with the terminal for Bluetooth; the other is a charging cradle, which only supports the charging function.

1-4 Parts of the terminal

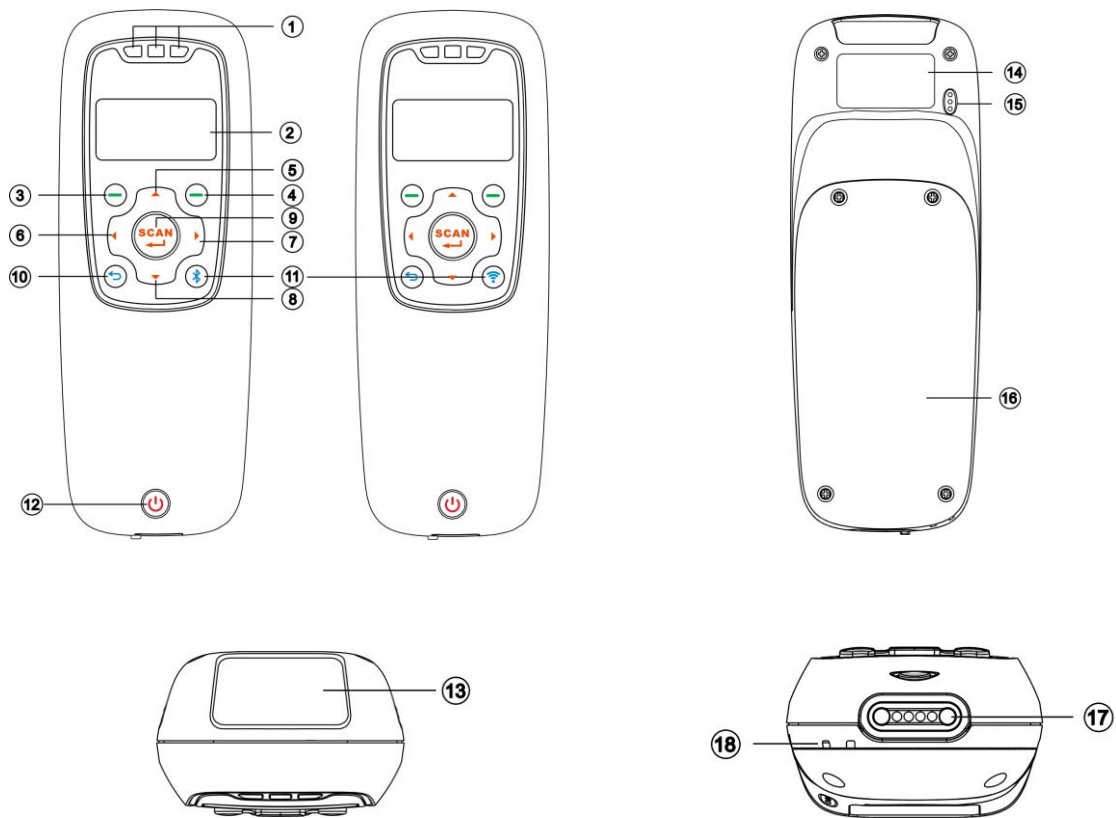

Figure 1-3 Parts of the terminal

- ① Blue LED (Bluetooth power); Green LED (Decode success); Red LED (Charging indicator)
- ② OLED
- ③ Left soft key
- ④ Right soft key
- ⑤ Up navigation key
- ⑥ Left navigation key
- ⑦ Right navigation key
- ⑧ Down navigation key
- ⑨ Scan/Select key
- ⑩ Return key
- ⑪ Bluetooth or Wi-Fi on/off key
- ⑫ Power/Sleep key
- ⑬ Scan window
- ⑭ Label
- ⑮ Beeper
- ⑯ Battery cover
- ⑰ Mini USB port / Battery charging port (Lift cover)
- ⑱ Hook for neck/wrist strap

1-5 Introduction of keys

Operations, such as scrolling and selecting menus, moving a cursor, or scanning a barcode, are controlled by trigger keys and stroke keys.

Key/Action/Feature	Part Position ¹	Description
Left soft key	③	Functionalities are identified by the screen display. In general, the acknowledge/non-acknowledge of operations are done by pressing a soft key.
Right soft key	④	
Scan/Select key	⑨	Press to scan barcodes when the terminal is not in a menu status; the select key is pressed to select items when a menu is activated.
Up navigation key	⑤	Press to move cursor upward/downward.
Down navigation key	⑧	
Left navigation key	⑥	Press to move cursor leftward/rightward.
Right navigation key	⑦	
Return key	⑩	Press to return to previous menu by one step.
Bluetooth or Wi-Fi on/off key	⑪	Press to turn on/off the Bluetooth power.
Power/Sleep key	⑫	Long press to power on/off a terminal; Short press to enter/exit sleep mode.

Note: ¹See [1-4 Parts of the terminal](#) for the information about position of keys.

1-6 Parts of the cradle

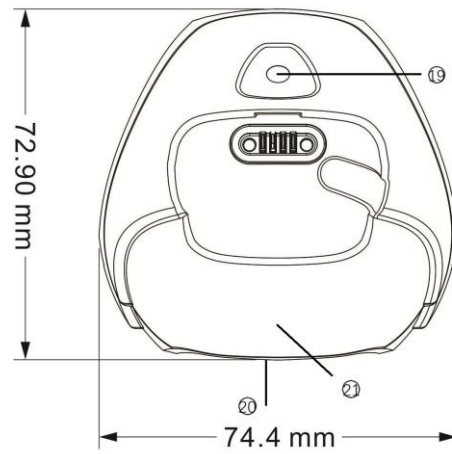

Figure 1-4 Parts of the cradle

- ①⑨ Charging (Green)
- ①⑩ USB interface
- ①⑪ Firmware upgrade key

2 Introduction of installation

2-1 Installing a USB HID keyboard wired terminal

Note: The default interface of the terminal is Bluetooth/Wi-Fi. Please change the interface to USB HID Keyboard (See [5-2 Data Transfer](#)).

- 1) Refer to Figure 2-1, plug one end of the USB cable to the terminal. Plug the other end into the USB port of the computer.
- 2) For example: Using Microsoft Windows operation system, the system gives message on “new hardware found – USB HID input device found”, then driver will be installed on request.
- 3) After successfully installing the new hardware, message will be given: “hardware installed successfully and ready to use”.
- 4) If any problem is encountered during the installation process, unplug the USB cable from the computer and repeat step 1-2.

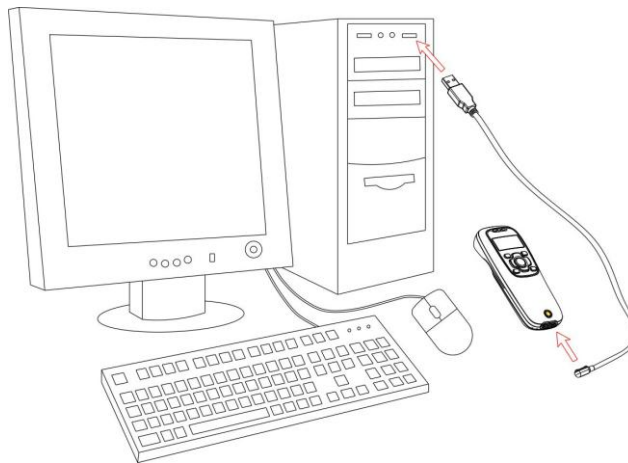

Figure 2-1 Diagram of connecting the terminal to PC

2-2 Installing a USB virtual COM wired terminal

Note: The default interface of the terminal is BT HID Keyboard. Please change the interface to USB Virtual COM (See [5-2 Data Transfer](#)).

- 1) Refer to Figure 2-1, plug one end of the USB cable to the terminal. Plug the other end into the USB port of the computer.
- 2) For example: Using Microsoft Windows operation system, the system gives message on “new hardware found – USB Virtual COM found” for USB virtual COM, then driver will be installed on request.
- 3) After successfully installing the new hardware, message will be given: “hardware installed successfully and ready to use”.
- 4) If any problem is encountered during the installation process, unplug the USB cable from the computer and repeat step 1 to step 2.

2-3 Replacing the Lithium-ion battery

- 1) Remove the 3 screws from the battery cover (one at a time).
- 2) Refer to Figure 2-3, load the battery while sliding it with the connection on the battery pack on the terminal body.
- 3) Re-place the battery cover, screw in the 3 screws to tighten the terminal and the battery cover.

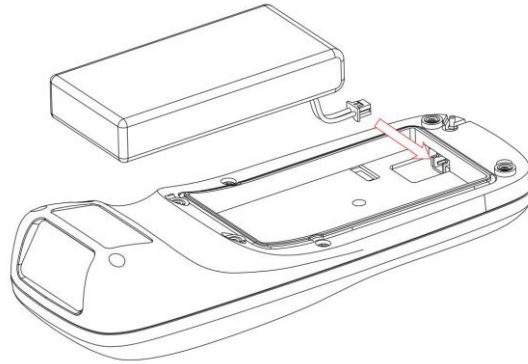

Figure 2-2 Diagram of replacing the Lithium-ion battery

3 Getting started

3-1 Power on/off terminal

Power on terminal: Press the Power/Sleep key  for two seconds.

Power off terminal: Press the Power/Sleep key  for two seconds.

3-2 Charge terminal

- 1) **Please charge the terminal before the first time of use.** There are three methods of charging battery as demonstrated in Figure 3-1. The charging indicator (red LED) on the terminal is turned on when the charging is in process. When the charging process completes, the red LED is turned off.
- 2) Charging time: 3.5 hours for fully charged.
- 3) In scanning status, the icon  is seen at the top of the screen display when the terminal is connected to a PC with the USB cable.

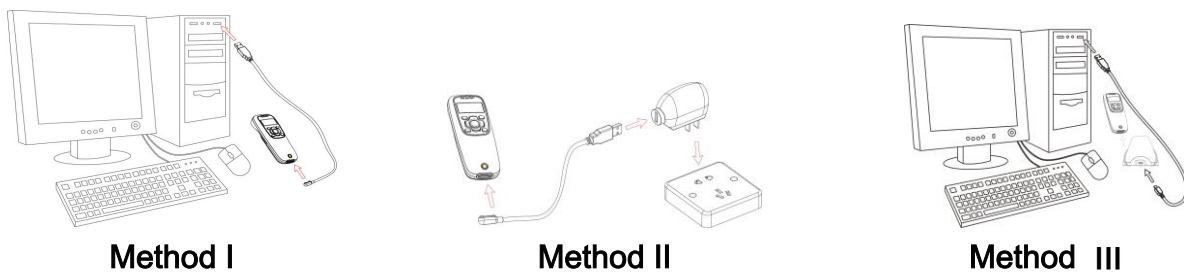



Figure 3-1 Diagram of charging battery



3-3 Enter/Exit sleep mode

Enter sleep mode: Press the Power/Sleep key  (see [1-4 Parts of the terminal](#) ⑫) for 0.5 seconds.

Exit sleep mode: Press the Power/Sleep key  for 0.5 seconds.

3-4 Power on/off Bluetooth

Bluetooth indicator: In scanning status, the status of the Bluetooth is shown by icons.

	Bluetooth is off
	Bluetooth is on
	Communicating with a Bluetooth device

The status of the Bluetooth is also indicated by the blue LED.



on	Bluetooth is on.
off	Bluetooth is off.

Power off Bluetooth: Press the Bluetooth key .

Power on Bluetooth: Press the Bluetooth key .

3-5 Power on/off Wi-Fi

Wi-Fi indicator: In scanning status, the status of the Wi-Fi is shown by icons.

	Wi-Fi is on
	Communicating with a Wi-Fi network

The status of the Wi-Fi is also indicated by the blue LED.

on	Wi-Fi is on.
off	Wi-Fi is off.

Power off Wi-Fi: Press the Wi-Fi key .

Power on Wi-Fi: Press the Wi-Fi key .









4 Introduction of OLED display

4-1 OLED display icons

Note:

- 1) The OLED screen is designed to display barcode scanning, Bluetooth/Wi-Fi network establishing, data transfer, system setting and other information.
- 2) The display area is 64 dots (V) by 128 dots (H). The backlight will be switched off automatically if time of no operation exceeds a programmable duration (see [5-3 System setting](#)).

Table 4-1 OLED display icons

Icon	Description
	Bluetooth is off
	Bluetooth is on
	Communicating with a Bluetooth device
	Wi-Fi is on
	Communicating with a Wi-Fi network
	Terminal is connected to a PC (or other instrument) with USB cable.
	Support for switching among the input of barcode scanning and the virtual keyboard on Apple iOS, such as Apple iPad.
	Battery capacity (from the left): <ul style="list-style-type: none">• Battery is fully charged (100% - 75% charge remains).• 75% - 50% charge remains.• 50% - 25% charge remains.• 25% - 10% charge remains.• 10% - no charge remains. When the battery capacity is lower than 10%, the battery icon blinks and an error tone sounds once every minute.

4-2 OLED display menu

The Home menu consists of five items, which are described in details in the following chapters. Table 4-2 depicts the hierarchy chart of the OLED display menu.

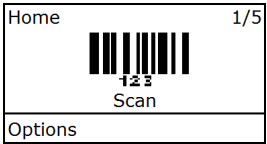
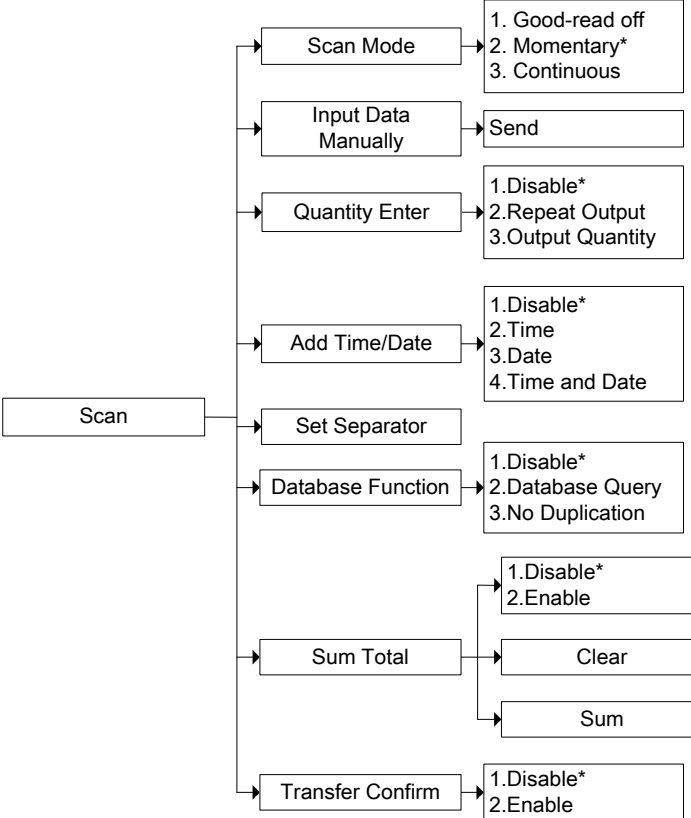

Note: Items that are labeled ‘*’ are default selections.

Table 4-2 OLED display menu

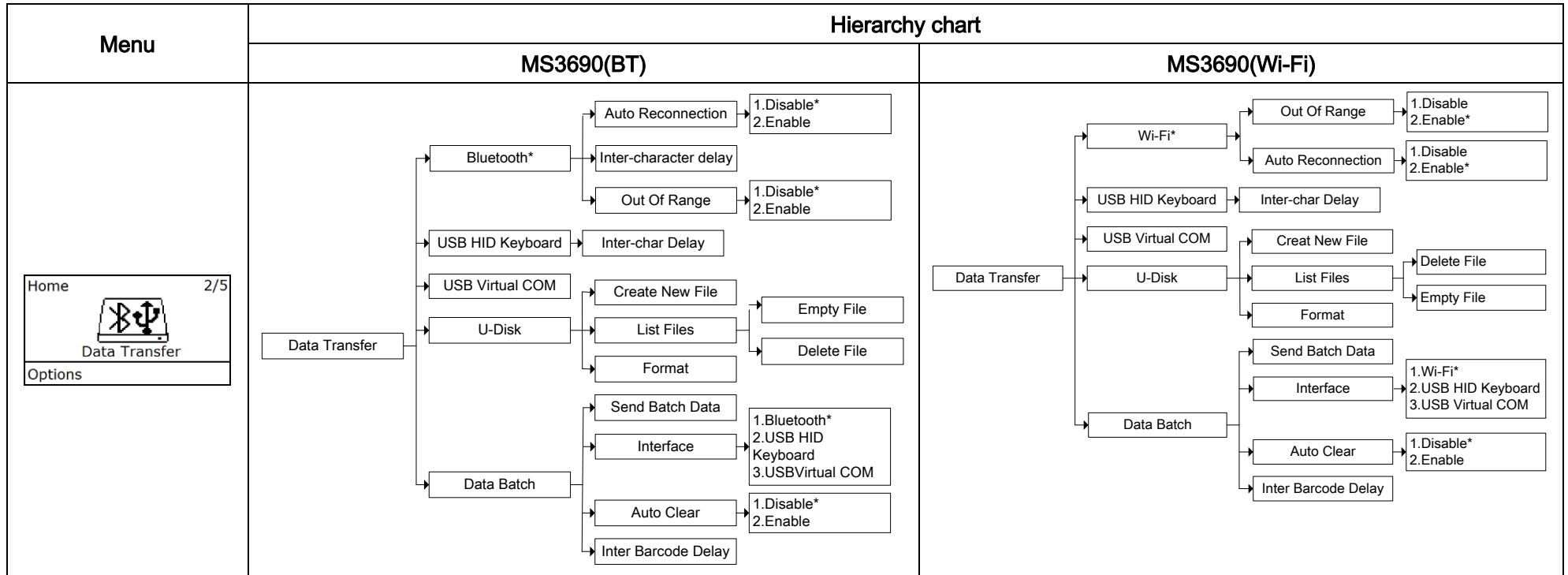
Menu	Hierarchy chart	
	MS3690(BT)	MS3690(Wi-Fi)
	 <pre> graph LR Scan[Scan] --> SM[Scan Mode] Scan --> IDMI[Input Data Manually] Scan --> QE[Quantity Enter] Scan --> ATD[Add Time/Date] Scan --> SS[Set Separator] Scan --> DF[Database Function] Scan --> ST[Sum Total] Scan --> TC[Transfer Confirm] SM --> SM1[1. Good-read off] SM --> SM2[2. Momentary*] SM --> SM3[3. Continuous] IDMI --> IDMI1[Send] QE --> QE1[1.Disable*] QE --> QE2[2.Repeat Output] QE --> QE3[3.Output Quantity] ATD --> ATD1[1.Disable*] ATD --> ATD2[2.Time] ATD --> ATD3[3.Date] ATD --> ATD4[4.Time and Date] SS --> SS1[1.Disable*] DF --> DF1[1.Disable*] DF --> DF2[2.Database Query] DF --> DF3[3.No Duplication] ST --> ST1[1.Disable*] ST --> ST2[2.Enable] ST --> ST3[Clear] ST --> ST4[Sum] TC --> TC1[1.Disable*] TC --> TC2[2.Enable] </pre>	

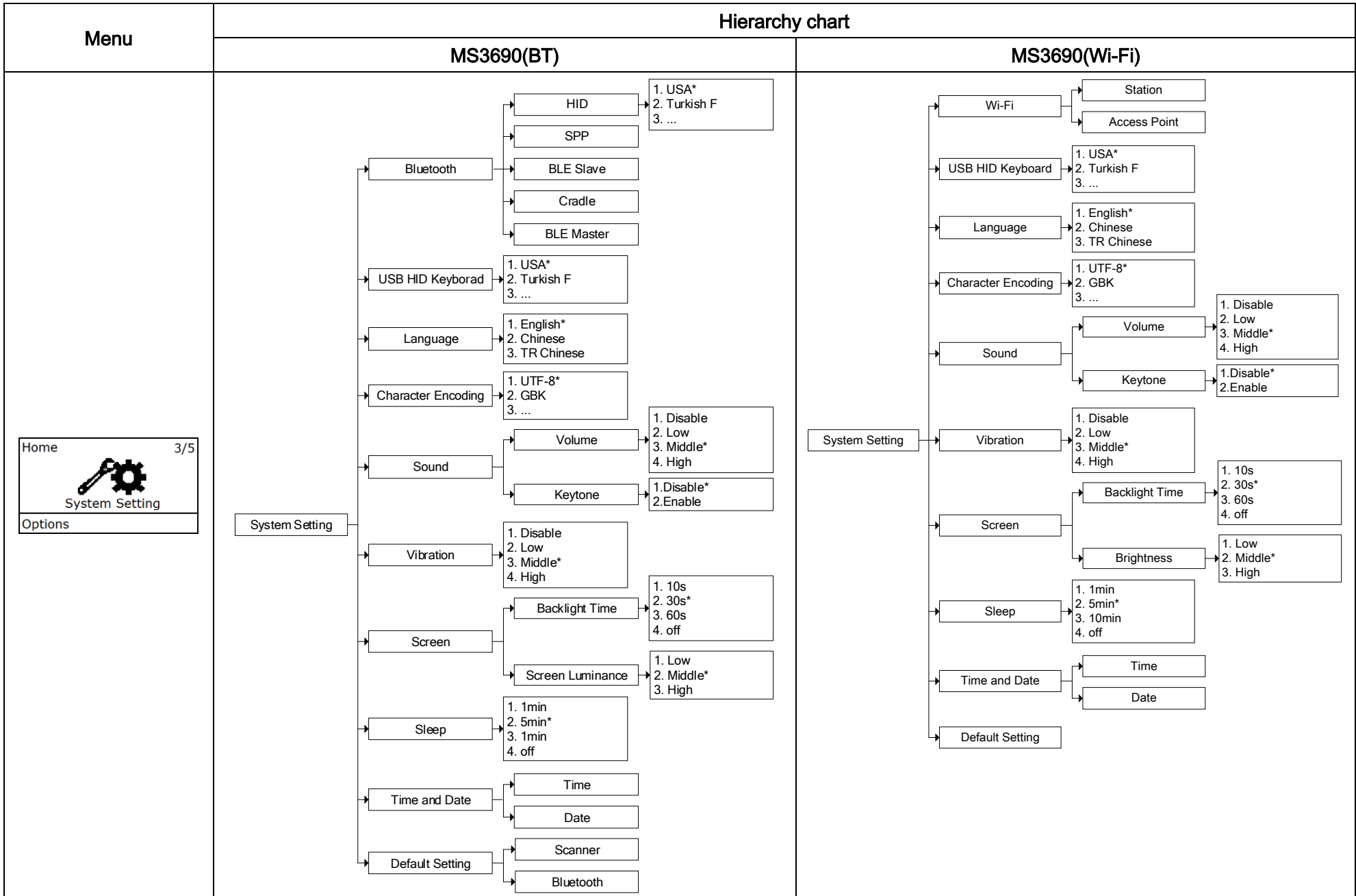



Menu	Hierarchy chart	
	MS3690(BT)	MS3690(Wi-Fi)
<div data-bbox="147 363 412 501"> <p>Home 4/5</p>  <p>System Information</p> <p>Options</p> </div>	<div data-bbox="450 268 1182 448"> <pre> graph LR SI[System Information] --> VM[View Memory] SI --> BI[Bluetooth Info] SI --> FV[Firmware Version] VM --> E[Erase] FV --> S[Scanner] FV --> SE[Scan Engine] </pre> </div>	<div data-bbox="1301 268 2033 584"> <pre> graph LR SI[System Information] --> VM[View Memory] SI --> WFI[Wi-Fi Information] SI --> FV[Firmware Version] VM --> E[Erase] WFI --> CI[Connection Info] WFI --> IP[IP Info] WFI --> SI2[Socket Info] FV --> S[Scanner] FV --> SE[Scan Engine] </pre> </div>
<div data-bbox="147 639 412 780"> <p>Home 5/5</p>  <p>Application</p> <p>Options</p> </div>	<div data-bbox="909 635 1619 794"> <pre> graph LR A[Application] --> AR[Auto Run] A --> E[Execute] A --> D[Download] AR --> AR_O["1.Disable* 2.Enable"] </pre> </div>	

5 Operations of the terminal

Note:

1. Please establish a Bluetooth/Wi-Fi network and hold the terminal in the range of the network before the first time of scanning barcodes (See [5-3-1 Bluetooth](#) and [5-3-2 Wi-Fi](#)).
2. The terminal can perform a barcode scan operation even though no Bluetooth/Wi-Fi network is available. However, the terminal may react in a way that differs from what is described here if no Bluetooth/Wi-Fi network is working.

5-1 Scan

Steps:

Step 1: When the terminal is powered on, the OLED screen is displayed as below.

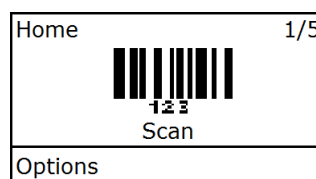

Step 2: Hold the terminal close to the barcode and press the Scan Key  .

Step 3: The terminal port emits a laser to scan the barcode. The decode success indicator lights green when the scan is successful. The window will show as below.

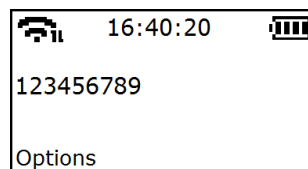
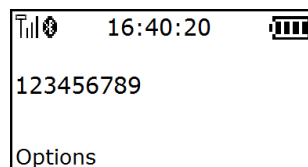

5-1-1 Scan Mode

Good-read off - The Scan key must be pressed once to activate scanning. The light source of terminal stops scanning when there is a successful reading or no code is decoded after the Stand-by duration elapsed.

Momentary - The Scan key acts as a switch. Press the key to activate scanning and release the key to stop scanning. The light source of terminal stops scanning when there is a successful reading or no code is decoded after the Stand-by duration elapsed.

Continuous - The terminal always keeps scanning, and it does not matter when the Scan key is released or duration is elapsed.

Note: 2D Model do not support "Continuous" mode.

5-1-2 Input Data Manually

Using the virtual keypad, user can input a barcode manually, and then send the barcode to the host or store in the terminal. (The maximum length of barcode is 20.)

Make sure a communication link (Bluetooth/Wi-Fi network or USB cable) is working.

5-1-3 Quantity Enter

User can disable the Quantity Enter and select Repeat Output mode or Output Quantity mode. When Quantity Enter is enabled, user can set the number (0 to 9999) of barcode transmissions. For example, a barcode "123456789" is read. When user select Repeat Output mode, Five "123456789" will be received by the host, given that the quantity is 5. When user selects Output Quantity mode, "123456789*5" will be received by the host, given that the quantity is 5. The quantity decides how many identify barcodes a host receives upon a single successful read.

The following steps demonstrate the procedure to set a quantity.

Step 1: Enable Quantity Enter, press the Scan Key to read a barcode.

Example display:

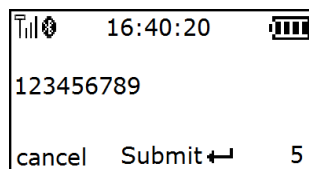

Step 2: Press Right Soft Key to the window below.

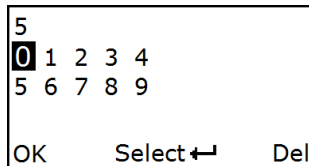

Step 3: Use Navigation Keys to move the cursor, Scan/Select Key to select number(s), Right Soft Key to delete selected number(s). And then press Left Soft Key to continue.

5-1-4 Add Time/Date

The time information can be added as an appendix to a barcode by enabling the Add Time.

For example:

When Add Time is enabled, a barcode "123456789" is read in 12:00:00, "123456789*12:00:00" will be received by the host.

The date information can be added as an appendix to a barcode by enabling the Add Date.

For example:

When Add Date is enabled, a barcode "123456789" is read at 25.05.2012, "123456789, 25.05.2012" will be received by the host.

The time and date information can be added as an appendix to a barcode by enabling the Add Time and Date.

For example:

When Add Time and Add Date is enabled, a barcode “123456789” is read in 12:00:00 at 25.05.2012, “123456789,12:00:00, 25.05.2012” will be received by the host.

5-1-5 Set Separator

The barcode and Time/Data/quantity will be separated by separator, the default separator is comma <,>. By using the virtual keypad, user can input character manually. The length of the separator string can be at most 8 characters.

Example1: A barcode “123456789” is read in 12:00:00 at 25.05.2012. When user selects Output Quantity mode, “123456789, 5” will be received by the host, given that the quantity is 5.

123456789*5*12:00:00*25.05.2012

Example2: When user enables the Data Statistics, the barcode and quantity will be separated, the eighth barcode is “123456789” in the example below.

123456789*8

5-1-6 Database Function

5-1-6-1 Database Query

Database query includes: After successfully scanning the barcode, the barcode information would be displayed on the OLED screen. The database query function demands the use of MS3 DB database supporting software tool to generate database files: *.IDX and *.DAT. By applying the database query functionality, the user can rapidly and accurately locate the barcode information.

When user scan the barcode, the terminal would perform a database searching upon the database files stored in the flash disk and display the barcode information if matching is found when the database query function is enabled. User would require scrolling to left or right for more information displayed on the OLED screen. If no matching is found then “No Record” is displayed on the OLED screen.

Example:

User barcode information as follows:

	A	B	C	D
1	Barcode	Trade Name	Price	Place of Production
2	12345670	Computer	¥ 3000.00	Shenzhen

When user scan the barcode “12345670”, The terminal would display “Computer, ¥ 3000.00 , Shenzhen” on the OLED screen.

Note: The default database files are named SYS_DB.IDX and SYS_DB.DAT. In order to utilize the database functionality user should NOT change these file names and these two files are properly stored to the flash disk.

5-1-6-2 No Duplication

When user scans the barcode, the terminal retrieves the database for a match in the meantime. If the barcode does not exist in the database, the barcode will be recorded into the database file, sent out or stored in USB Disk. Neither transmission nor store operation will be performed if a barcode already exists in the database. Furthermore, the “Barcode already exists” message is displayed on the OLED screen.

User can clear the previous barcode record by entering the same barcode avoidance setting menu page and pressing the left soft key (**clear**).

5-1-6-3 Database List

This menu can be selected to list all database files in the root directory. The file selected to be the target file is labeled ✓. The operations described below are imposed to the cursor-on file, which is not necessary to be the target file.

Example:

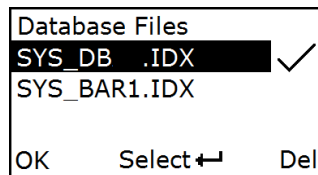

5-1-7 Sum Total

The terminal will automatically count and display the number of the whole barcodes which have been sent or stored successfully when Barcode Statistics function is enabled.

User can clear the previous barcode record by entering the barcode statistic function setting menu page and pressing the left soft key (**clear**).

5-1-8 Transfer Confirm

User can select to enable/disable the transfer confirm. When the scan is successful, The terminal would point out that whether confirm to transfer this barcode. User can press left soft key to cancel transfer or press right soft key to confirm transfer barcode data.

5-2 Data Transfer

5-2-1 Bluetooth

See [5-3 System Setting - Bluetooth](#) for instructions to establish a Bluetooth network. Three options are listed below.

Auto reconnection- When terminal's Bluetooth is power on, it will try to establish the wireless connection with the host which it last connected, if Auto Reconnection is enabled.

Inter-char delay- Inter-character delay is abbreviated to Inter-char delay. This delay is inserted after each data character transmitted when configure Bluetooth to HID keyboard profile. Some Bluetooth communication needs large delay to avoid data missing. This default delay is set to 8 milliseconds.

5-2-5-2 List Files

This menu can be selected to list all files in the root directory. The file selected to be the target file is labeled √. The operations described below are imposed to the cursor-on file, which is not necessary to be the target file.

Example:

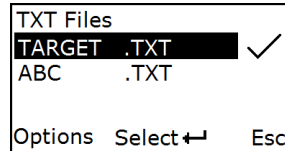

Options Menu

Note: Press Left Soft Key to popup this menu.



Caution:

Empty and Delete operations are not undoable. It is strongly recommended to back up the data before empty or delete operation.

A) Empty/Delete Files

If the U-disk is almost full, occupied room can be released by emptying/deleting some files.

A target file is protected by system and prevented from being deleting. In this case, the file that is wanted to be deleted should be deselected and then deleted.

5-2-5-3 Format

Note 1: The format function is a quick way to empty a whole U Disk.

Note 2: Please format the U Disk once before the first time of use.



Caution:

1. Format operation will erase all data on the disk.
2. Format operation is not undoable. It is strongly recommended to back up the data before format operation.

5-2-6 Data batch

The terminal starts storing barcode data in Date Batch mode. The collected barcode data can then be sent to a host via Bluetooth/USB. Three options are listed below.

Send batch data - Data transmission is triggered by this menu command. Before undertaking this operation, make sure a communication link (Bluetooth network or USB cable) is working.

Interfaces - There are three types of communication interfaces Bluetooth, USB HID keyboard and USB virtual COM. A Bluetooth link is needed in the first case (See [5-3 System Setting - Bluetooth](#)).

Auto Clear – By enable, the terminal will clear the stored barcode after finishing sending, if Auto Clear is enabled.

Inter Barcode Delay – set the delay time for transmission of data

5-3 System Setting

5-3-1 Bluetooth Functionalities

The terminal can be configured to send data to a PC/Notebook/PDA/other instrument which has an integrated Bluetooth module or is connected with an external Bluetooth USB adapter. A diagram of Bluetooth functionalities and a table of various Bluetooth profiles are shown below, respectively:

Table 5-1 Various Bluetooth profiles

HID Keyboard	The terminal connects to the PC/host via Bluetooth and behaves like a keyboard. The terminal accepts incoming connection requested from a remote device and is the slave.
SPP	The terminal connects to the PC/host via Bluetooth and behaves like there is a serial connection.
BLE slave	A Bluetooth 4.0 device will pair with the terminal, so that the terminal can transfer data with low power.
Cradle	The terminal connects to the PC via cradle and behaves like a keyboard.
BLE master	Only use in MS3 SDK

Note: Bluetooth-enabled smart phones and PDAs can host the terminal in general. However, ordinary mobile phones with Bluetooth function can not be a host of the terminal because in most cases neither HID nor SPP profile is supported by them.

5-3-1-1 Configure Bluetooth HID Keyboard profile communication

Note : make sure the Bluetooth module of the terminal is powered on (blue LED is on) and the selected profile is HID Keyboard.

Step 1: Plug a Bluetooth USB adapter into the USB port of the computer.

Step 2: Double-click the Bluetooth icon at the right bottom corner on Windows 7 ().

Step 3: Click **Add** to search devices nearby.

Step 4: Select the terminal you want to connect and then click **Next**.

Step 5: You can change the name through the terminal(System Information-> Bluetooth Info)

Step 6: The terminal use the simple pair mode. If a pair code popping, you can directly select **YES** and click **Next**, and then you can finish the connection.

Name: MIND Addr: F45EABD9868F Ver: 8.6.0 Name
--

5-3-1-2 Configure Bluetooth SPP profile communication

Note : Make sure the Bluetooth module of the terminal is powered on (blue LED is on) and the selected profile is SPP.

Step 1: Press Left Soft Key to the SPP List, if no connection record, press Left Soft Key to search. Wait for about 20 seconds and then the devices list will be shown

Step 2: Use Navigation Key to move the cursor and press Scan/Select Key to connect. The Bluetooth device connected to the terminal is labeled ✓. And then you can press Right Soft Key to disconnect.

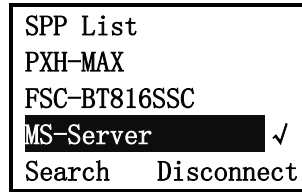

5-3-1-3 Configure Bluetooth BLE Slave profile communication

Note: Make sure the Bluetooth module of the terminal is powered on (blue LED is on), and the selected profile is System Setting→Bluetooth→BLE.

Step 1: Connect to Bluetooth 4.0 device and transmit data in low power mode.

5-3-1-4 Configure Bluetooth Cradle

Note1: Cradle is provided by the manufacturer to support reliable wireless data transmission, and it is advised in applications whereas unacknowledged communication is unacceptable.

Note2: Make sure the Bluetooth module of the terminal is powered on (blue LED is on).

Note3: The default cradle transmission interface is a USB HID keyboard, and the optional interface is a USB virtual serial port.

Note4: If you choose USB HID keyboard mode, can set the keyboard layout (default US keyboard), transmission speed, number keys.

There are two methods to setup the Bluetooth communication.

Method I: scanning special barcode.

Step 1: Scan the barcode on the back of Cradle. The terminal will beep twice to indicate a successful scanning

Step 2: Connect Cradle to a PC within 10 seconds. Then wait for about 5 seconds. The terminal will give 2 long beeps upon a successful connection, or 3 short beeps upon a failed connection.



An example of barcode to indicate a Cradle

Method II: operating the terminal on the OLED screen.

Step1. Press Left Soft Key towards the window below. If the terminal has no connection record, it will show the indication of “There is no connection record.”

Step2. Press **Search** to the window below for searching.

Step3. Wait for about 20 seconds and then Cradle list will be shown.

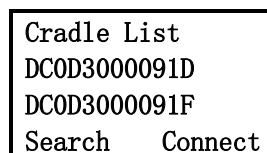

Step4. Use Navigation Key to move the cursor and press Scan/Select Key to connect with Cradle.

Step5. Wait for about 3 seconds, the terminal will respond with 2 long beeps upon successful connection.

Step6. The Cradle connected to the terminal is labeled ✓.

Step7. If you want to disconnect the cradle connected successfully before, you can press Scan/Select Key to disconnect it.

Cradle List
DCOD3000091D
DCOD3000091F ✓
Search Disconnect

5-3-2 Wi-Fi

The terminal can be configured to send data to a PC, Notebook, PDA, and other instrument which equipped with an integrated Wi-Fi module or receive data from these instruments under the same WLAN. Two wireless operating modes have been provided: Station Mode and Access Point Mode.

5-3-2-1 Station Mode

- 1) The terminal is used as a client and the other devices are used as servers in the same WLAN.
- 2) The terminal can connect to WLAN by wireless router and communicate with other devices that connect to the same WLAN.
- 3) The terminal initiates a connection to the servers and it can support up to 8 connections.
- 4) The terminal can only set up one communication channel with host at a time. It also can switch to another channel for communicating with another host.

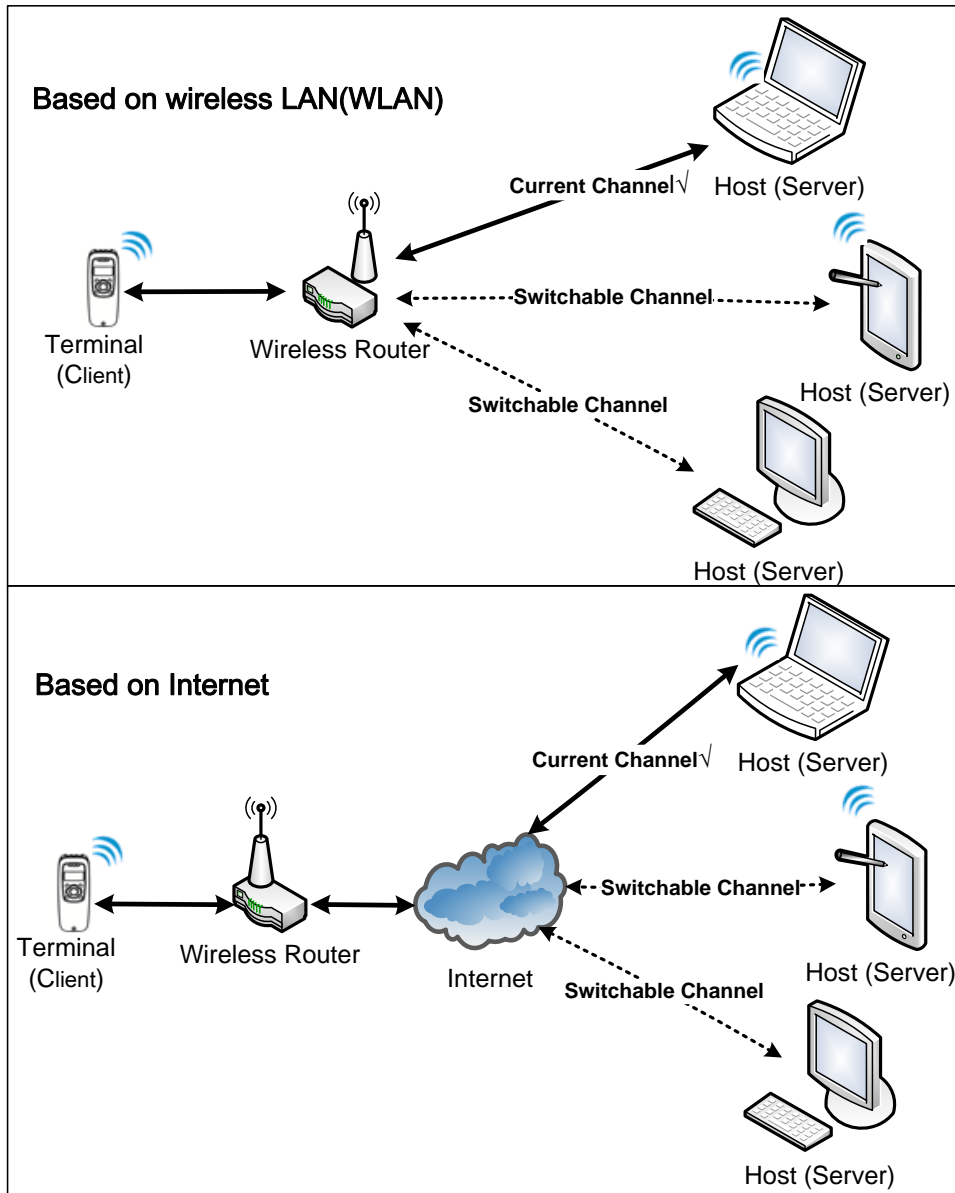
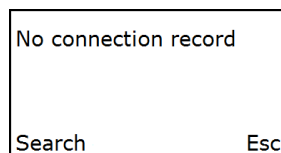

Figure 5-1 Station Mode

Set Wi-Fi Station Mode for data communication. The steps are as follows.

Step 1: Search for WLAN and bond with devices in Station Mode. Enter the Station Mode setting menu.

When there has no connection record, the terminal will show information as follow:



Step 2: Press Left-Soft Key to search for device.

Step 3: Wait for about 3 seconds, the terminal will list the serviceable WLAN around. "🔒" indicates that the password-protected WLAN which needs the passphrase for accessing the wireless network. The screen shows as follow:

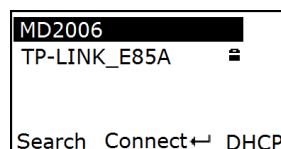

Step 4: Press the Right-Soft Key to enter the DHCP setting menu, press the navigational key to select

whether enable DHCP, and press the Scan/Select Key to confirm. If disable the DHCP, you should input the static address for the terminal. The screen shows as follow:

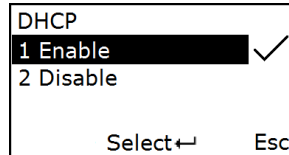

Step 5: Press the navigational key to select the target WLAN, and press the Scan/Select Key to connect the WLAN. If connect a password-protected WLAN, you should input passphrase.

Step 6: The terminal use the icon “√” to indicate which WLAN has been connected. Press Scan/Select Key to disconnect the WLAN. The screen shows as follow:

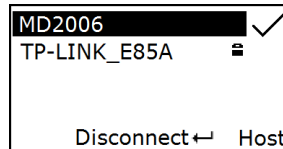

Step 7: Press Right-Soft Key to display the **Host Lists Menu**. In **Host Lists Menu**, press the navigational key to select the target host IP. The screen shows as follow:

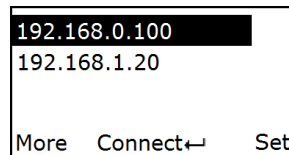

Press **More** to add/delete the hostIP

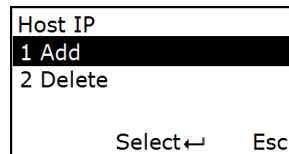

Press **Set** to set the socket.

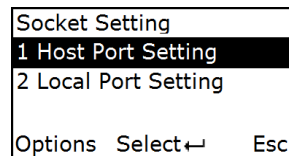

Step 8: Press Scan/Select Key to bond with the target host. “⌚” indicate the connecting process.

If the terminal connects the host success, it will use “🔗” icon to indicate the link state, and use the icon “√” to indicate the target communicating host. If it has been set up multiple communication channels for bonding with the host(Up to 8 channels), press the navigational key to move the cursor, then press the Scan/Select key to select the target communicating host. The screen will show information as follow:

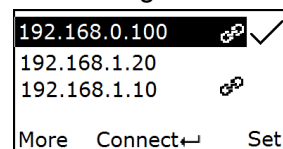

Notice:

1. Make sure the target host has been set up as a server and open the TCP/IP service, or it cannot set up the communication channel with host successfully.
2. If the target host address is a domain name, ensure the DNS setting of the terminal is open; If the target host address is an IP address, ensure that the DNS setting of the terminal is closed.

5-3-2-2 Access Point Mode

- 1) The terminal is used as a server and the other devices are used as clients in the same WLAN. The other devices initiate a connection to the server.
- 2) The terminal can set up a WLAN and communicate with other devices that connect with the terminal.
- 3) The client initiates a connection to the server and it only supports one connection at a time.

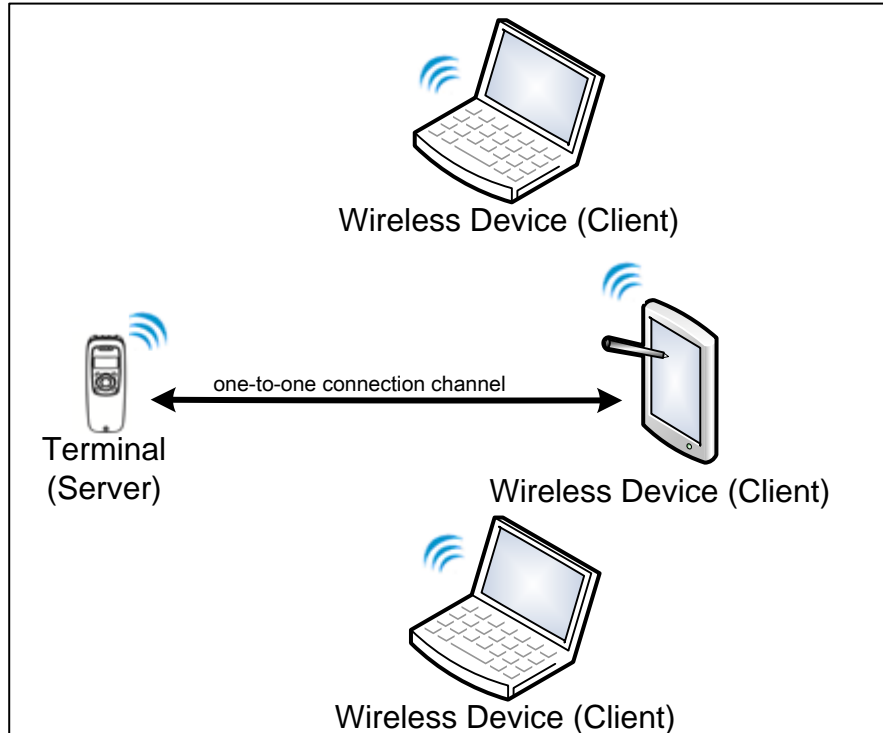

Figure 5-2 Access Point Mode

Set Wi-Fi Access Point Mode for data communication. The steps are as follows.

Step 1: When enter the **Access Point Setting Menu**. The screen shows as follow:

```
Access Point
SSID: MIND
PSK: 11112222

          SetUp ←   Set
```

Press Up-Soft Key to get IP and port.

```
Access Point
IP: 192.168.0.122
Port: 8080

          SetUp ←   Set
```

Step 2: Press **Set** to change SSID, Passphrase, IP and Port.

```
AP Setting
1. SSID Setting
2. Passphrase Setting
3. IP Setting
Options Select ←   Esc
```

Step 3: Press **SetUp** to Set up a hot point.

```
Access Point
SSID: MIND
PSK: 11112222

View      Stop ←   Esc
```

Step 4: Press **View** to view the connected device. If no device connected, it will show “0 device”. The screen shows as follow:

```
0 device.

                               Esc
```

5-3-3 USB HID Keyboard

Keyboard layout – supports different national keyboard layouts.

5-3-4 Language

This option is used to select a language for menu display.

5-3-5 Character Encoding

A character encoding system consists of a code that pairs each character from a given repertoire. Common examples include Morse code, Baudot code, ASCII, UTF_8 and Unicode. If the data received does not display with the proper characters, it may be because the barcode being scanned was created using a character encoding system that is different from the one the host program is expecting. Try alternate options to find the proper one.

5-3-6 Sound

Volume - This option is used to control the beeper volume.

Keystone - This option is used to turn on/off the Keystone

5-3-7 Vibration

This option is used to turn on/off the vibrator indicator of a good read.

5-3-8 Screen

Backlight Time - The terminal will switch off the backlight if time of no operation exceeds Backlight timeout.

Screen Luminance - This option is used to set screen luminance.

5-3-9 Sleep

The terminal will enter sleep mode if time of no operation exceeds **Sleeping timeout**. User can set the terminal to sleep mode by press Power/Sleep key (see [3-3 Enter/exit sleep mode](#)).

5-3-10 Time and Date

The option is used to set the time and the date of the terminal.

5-3-11 Default Setting

All parameters of the terminal return to default setting.

Table 5-2 Default setting of terminal

Items	Option
Language	English* Chinese TR Chinese
character encoding	UTF-8* GBK Big5
Volume	Off Low Middle* High
Keystone	Disable* Enable
Vibration	Disable* Enable

Backlight timeout	10s 30s* 60s Off
Screen Luminance	Low Middle* High
Sleeping timeout	1min 5min* 10min Off

5-4 System Information

5-4-1 View Memory

Note: User can press Left Soft Key to erase data to release used memory.

User can view the used and remain memory capacity in Batch Mode.

```
Total: 8259584   bytes
Used: 0         bytes
Free: 8259584   bytes

Erase           Esc
```



Caution:

1. Erasing operation will delete all data in the memory.
2. Erasing operation is not undoable.

5-4-2 Bluetooth

User can view the name and address of the Bluetooth module.

Example:

```
Name: MIND
Addr: F45EABD9868F
Ver: 8.6.0

Name
```

5-4-3 Wi-Fi

Wi-Fi information includes the current wireless operating mode, connection information, IP, and socket information. The screen shows as follow.

```
Operating Mode
1. Connection Info
2. IP Info
3. Socket Info

Options  Select+↵  Esc
```

5-4-4 Firmware Version

User can view the firmware version of the terminal and scan engine.

6 User customized application software for MS3690

With the support of MS3 SDK, The terminal supports user customized application software development. User customized application software is developed with the support of the terminal system API. For more detail about user customized application software development please refer to the MS3 SDK help files.

6-1 Auto Run

When this option is enabled the terminal would automatically runs the user customized application software after boots. When user keep pressing the right soft key during system booting stage, the system password is required before entering the system state. Entering the system state is only allowed after the correct password is provided. Pressing the return key could lead to the user customized application software state.

Note: It only works after successfully downloaded the user customized application software.

6-2 Execute

User could execute the user customized application software by entering the “Execute” menu. Please be sure the user customized application software is properly downloaded to the terminal before execution.

6-3 Download

Enter into this menu to download application by MS3 SDK;

Step 1: Power on the terminal, enter into the menu: Application->Download;

Step 2: Make sure of connecting the PC and the terminal well with USB cable;

Step3. Clicking on the button  in the toolbar of MS3 SDK to perform download BIN file or ENP file to the terminal;

Step4. After downloaded successfully, the terminal will respond with 2 short beeps.

7 Barcode programming instructions

7-1 Example: Setting parameter

Important notes:

- 1) During the process of programming, LED is lighting to indicate the programming correctness. LED will go off if any incorrect programming operation performed.
- 2) After each successful programming, LED will go off and the terminal will beep twice.
- 3) Throughout the programming barcode menus, the factory default settings are indicated with asterisks (*).

Two programming modes have been provided as bellows:

❶ Single-scan setting

Example 1: Disable UPC-A.



%1101D00%

Example 2: Enable UPC-A.



%1101D01%

Test barcode: UPC-A



❷ Multiple-scan setting (Mainly used for multi character settings)

Step 1: Scan the **Option barcode** barcode according to the user's demand.

Step 2: To the right of the option barcode, the necessary alphanumeric inputs are listed. Scan two alphanumeric entries from **0** to **9** or **A** to **F**, refer to [12 Configuration alphanumeric entry barcode](#).

Step 3: Repeat Step 2, if more user parameters input are required.

Step 4: Scan the **%END%** barcode, listed on the lower left hand corner of each parameter setting part.

Example 1: Set Prefix to bc.

Step 1: Set Prefix to bc.



%8001M%



6



2



6



3



%END%

Step 2: Enable Prefix transmission.









%8201D01%

7-2 Decode illumination and decode aiming pattern

Note: 1D Model do not support these features.

Decode illumination mode: Enable illumination causes the terminal to turn on the illumination to aid decoding. Disable illumination to turn off illumination for the terminal during decoding. Better quality images could be obtained with illumination support. The effectiveness of the illumination decreases as the distance to the target increases.

Decode aiming pattern: When this option is enabled, the terminal will project the aiming pattern during the code capture.











Items	Single-scan setting
Decode illumination	 %9001D00% Always Off
	 %9001D01% Always On
	 %9001D02% * On when reading
Decode aiming pattern	 %9002D00% Always Off
	 %9002D01% Always On
	 %9002D02% On before reading
	 %9002D03% * On when reading

7-3 Other setting

Note: 1D Model do not support these features.

2D symbols read: A global setting of 2D symbols readability.

Vertical centering read: By setting Enable, the terminal reads only the barcode centered by the aimer in vertical direction. However, the terminal will read either one of two barcodes which are positioned horizontally.

Items	Single-scan setting
2D symbols read	 %1001D00% * Follow respective 2D symbols setting
	 %1001D01% All 2D symbols OFF
	 %1001D02% All 2D symbols ON
	 %1001D03% Only PDF417 ON
	 %1001D04% Only QR code ON
	 %1001D05% Only Data Matrix ON
	 %1001D06% Only MaxiCode ON
	 %1001D07% Only Aztec Code ON
	 %1001D08% Only Han Xin Code ON
Vertical centering read	 %1004D00% * Disable
	 %1004D01% Enable

7-4 Scanning mode and some global settings

Scanning mode:

Good-read off -The trigger button must be pressed once to activate scanning. The light source of terminal stops scanning when there is a successful reading or no code is decoded after the **Stand-by duration** elapsed.

Momentary -The trigger button acts as a switch. Press button to activate scanning and release button to stop scanning. The light source of terminal stops scanning when there is a successful reading or no code is decoded after the **Stand-by duration** elapsed.

Continue -The trigger button acts as a toggle switch. Press button to activate or stop scanning.

Note: 2D Model do not support "Continuous" mode.

Same 1D barcode delay time: If a barcode has been scanned and output once successfully, the laser beam must be off or moved away from the barcode beyond delay time to active scanning the same barcode. When this feature is set to be "0xFF", then the delay time is indefinite.

Global Max./Min. code length for 1D barcode: These two lengths are defined as the valid range of decoded 1D barcode data length. Make sure that the minimum length setting is no greater than the maximum length setting, or otherwise the labels of the symbol will not be readable. In particular, the same value can be set for both minimum and maximum reading length to force the fixed length barcode decoded.

Note:

- 1) Please set the max./min. length for individual barcode in later sections, if special demand is requested.
- 2) The number of check digits is included in max./Min. code length.
- 3) These two settings have no effect on the symbols with fixed-length, e.g. UPC-A, UPC-E, EAN-13, EAN-8 and China Post.

Global G1-G4 string selection: The terminal offer one or two string group for ALL symbols. By setting one or two digits to indicate which string group you want to apply. You may refer to [7-33 G1-G4 & C1-C3 & FN1 substitution string setting](#) and [7-34 G1-G4 string position & Code ID position](#).















Example: Group 1 → set 01 or 10. Group 2 and 4 → set 24 or 42.





All valid settings include 00, 01, 02, 03, 04, 10, 11, 12, 13, 14, 20, 21, 22, 23, 24, 30, 31, 32, 33, 34, 40, 41, 42, 43, 44.

Character output restraint:

Printable character only- If this option is selected, the terminal will output the printable characters only, i.e. in ASCII from 20H to 7EH.

Alphanumeric character only- If this option is selected, the terminal will output the alphanumeric characters only, i.e. "A"-"Z", "a"-"z", "0"-"9".

Items	Single-scan setting
Scanning mode	 %0401D00% Good-read off
	 %0401D01% * Momentary
	 %0401D02% Continue (Only for 1D Model)
Standby duration	 %0402D40% * 4s (For 1D Model)
	 %0402D50% 5s (For 1D Model)
	 %0402D60% 6s (For 1D Model)
	 %0402D00% * 4s (For 2D Model)
	 %0402D01% 8s (For 2D Model)
	 %0402D02% 16s (For 2D Model)
Same 1D barcode delay time 01-99	 %0403D10% * 1s (For 1D Model)
	 %0403D20% 2s (For 1D Model)
	 %0403D30% 3s (For 1D Model)
Global Max. code length for 1D barcode 04-99	 %0405D99% * 99
Global Min. code length for 1D barcode 01-99	 %0406D04% * 04
Global G1-G4 string selection 00-44	 %0407D00% * None

Items	Single-scan setting
	 %0407D01% Insert G1 string
	 %0407D12% Insert G1 and G2 string
Character output restraint	 %0409D00% * None
	 %0409D01% Printable character only

7-5 UPC-A

Read:

Format

System character	Data digits (10 digits)	Check digit
------------------	-------------------------	-------------

Check digit transmission: By setting Enable, check digit will be transmitted.

Code ID setting: Code ID is a one-or-two-character string used to represent the symbol upon a succeeding reading. If you want application to transmit Code ID, you must set **Code ID transmission** to be enabled. Refer to [7-35 String transmission](#).

Insertion group selection: Refer to **Global insertion group selection** of [7-4 Scanning mode and some global settings](#).

Supplement digits: The Supplement digits barcode is the supplemental 2 or 5 characters.













Format

System character	Data digits (10 digits)	Check digit	Supplement digits 2 or 5
------------------	-------------------------	-------------	--------------------------

Truncation/Expansion:

Truncate leading zeros- The leading “0” digits of UPC-A data characters can be truncated when the feature is enabled.

Expand to EAN-13- It extends to 13-digits with a “0” leading digit when the feature is enabled.

Items	Single-scan setting
Read	 %1101D00% Disable
	 %1101D01% * Enable
Check digit transmission	 %1103D00% Disable
	 %1103D01% * Enable
Code ID setting 00-FF ₁₆ (ASCII)	 %1104H41% * <A>*
Insert group selection 00-44	 %1105D00% * None
Supplement digits	 %1106D00% * None
	 %1106D01% 2 digits
	 %1106D02% 5 digits
	 %1106D03% 2 or 5 digits
Truncation/Expansion	 %1107D00% * None
	 %1107D01% Truncate leading zeros
	 %1107D02% Expand to EAN-13

7-6 UPC-E

Read:

Format

System character "0"	Data digits (6 digits)	Check digits
----------------------	------------------------	--------------

Check digit transmission: By setting Enable, check digit will be transmitted.

Code ID setting: Refer to

Code ID setting

 of [7-5 UPC-A](#).

Insertion group selection: Refer to

Insertion group selection

 of [7-5 UPC-A](#).

Supplement digits:

Format

System character "0"	Data digits (6 digits)	Check digit	Supplement digits 2 or 5
----------------------	------------------------	-------------	--------------------------

Truncation/Expansion:

Truncate leading zeros- Refer to

Truncation/Expansion















 of [7-5 UPC-A](#).

Expand to EAN-13- It extends to 13-digits with "0" digits when the feature is set to be enabled.

Example: Barcode "0123654",

Output: "0012360000057".

Expand to UPC-A- It extends to 12-digits when the feature is set to be enabled.

Items	Single-scan setting
Read	 %1201D00% Disable
	 %1201D01% * Enable
Check digit transmission	 %1203D00% Disable
	 %1203D01% * Enable
Code ID setting 00-FF ₁₆ (ASCII)	 %1204H44% * <D>
Insert group selection 00-44	 %1205D00% * None
Supplement digits	 %1206D00% * None
	 %1206D01% 2 digits
	 %1206D02% 5 digits
	 %1206D03% 2 or 5 digits
Truncation/Expansion	 %1207D00% * None
	 %1207D01% Truncate leading zeros
	 %1207D02% Expand to EAN-13
	 %1207D03% Expand to UPC-A

7-7 UPC-E1

Read:

Format

System character "1"	Data digits (6 digits)	Check digits
----------------------	------------------------	--------------

Check digit transmission: By setting Enable, check digit will be transmitted.

Code ID setting: Refer to

Code ID setting

 of [7-5 UPC-A](#).

Insertion group selection: Refer to

Insertion group selection

 of [7-5 UPC-A](#).

Supplement digits:













Format

System character "1"	Data digits (6 digits)	Check digit	Supplement digits 2 or 5
----------------------	------------------------	-------------	--------------------------

Truncation/Expansion:

Expand to EAN-13- It extends to 13-digits with "0" digits when the feature is set to be enabled.

Expand to UPC-A- It extends to 12-digits when the feature is set to be enabled.

Items	Single-scan setting
Read	 %3401D00% Disable
	 %3401D01% * Enable
Check digit transmission	 %3403D00% Disable
	 %3403D01% * Enable
Code ID setting 00-FF ₁₆ (ASCII)	 %3404H44% * <D>
Insert group selection 00-44	 %3405D00% * None
Supplement digits	 %3406D00% * None
	 %3406D01% 2 digits
	 %3406D02% 5 digits
	 %3406D03% 2 or 5 digits
Truncation/Expansion	 %3407D00% * None
	 %3407D02% Expand to EAN-13
	 %3407D03% Expand to UPC-A

7-8 EAN-13 (ISBN/ISSN)

Read:

Format

Data digits (12 digits)	Check digit
-------------------------	-------------

Check digit transmission: By setting Enable, check digit will be transmitted.

EAN-13 code ID setting: Refer to Code ID setting of [7-5 UPC-A](#).

Insertion group selection: Refer to Insertion group selection of [7-5 UPC-A](#).

Supplement digits:

Format

Data digits (12 digits)	Check digit	Supplement digits 2 or 5
-------------------------	-------------	--------------------------













ISBN/ISSN conversion: The ISBN (International Standard Book Number, or Bookland EAN) and ISSN (International Standard Serial Number) are two kinds of barcode for books and magazines. The ISBN is 10 digits with leading “978” and the ISSN is 8 digits with leading “977” of the EAN-13 symbol.

Example:

Barcode “9780194315104”, Output: “019431510X”.

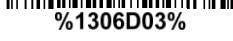
Barcode “9771005180004”, Output: “10051805”.

ISBN/ISSN code ID setting: Refer to Code ID setting of [7-5 UPC-A](#). (Only for 2D Model)

Items	Single-scan setting
Read	 %1301D00% Disable
	 %1301D01% * Enable
Check digit transmission	 %1303D00% Disable
	 %1303D01% * Enable
EAN-13 code ID setting 00-FF ₁₆ (ASCII)	 %1304H41% * <A>
Insert group selection 00-44	 %1305D00% * None
Supplement digits	 %1306D00% * None
	 %1306D01% 2 digits
	 %1306D02% 5 digits
	 %1306D03% 2 or 5 digits
ISBN/ISSN conversion	 %1307D00% * Disable
	 %1307D01% Enable
ISBN/ISSN code ID setting	 %1309H42% * (Only for 2D Model)

7-9 EAN-8

Read:

Format

Data digits (7 digits)	Check digit
------------------------	-------------

Check digit transmission: By setting Enable, check digit will be transmitted.

Code ID setting: Refer to

Code ID setting

 of [7-5 UPC-A](#).

Insertion group selection: Refer to

Insertion group selection

 of [7-5 UPC-A](#).

Supplement digits:







Format

Data digits (7 digits)	Check digit	Supplement Digits 2 or 5
------------------------	-------------	--------------------------

Truncation/Expansion: Refer to

Truncation/Expansion

 of [7-5 UPC-A](#).

Items	Single-scan setting
Read	 %1401D00% Disable
	 %1401D01% * Enable
Check digit transmission	 %1403D00% Disable
	 %1403D01% * Enable
Code ID setting 00-FF ₁₆ (ASCII)	 %1404H42% * <C>
Insert group selection 00-44	 %1405D00% * None
Supplement digits	 %1406D00% * None
	 %1406D01% 2 digits
	 %1406D02% 5 digits
	 %1406D03% 2 or 5 digits
Truncation/Expansion	 %1407D00% * None
	 %1407D01% Truncate leading zero
	 %1407D02% Expand to EAN-13

7-10 Code 39 (Code 32, Trioptic Code 39)

Read:

Format

Start character (*)	Data digits (variable)	Check digit (optional)	End character (*)
---------------------	------------------------	------------------------	-------------------

Check digit verification: The check digit is optional and made as the sum module 43 of the numerical value of the data digits.

Check digit transmission: By setting Enable, check digit will be transmitted.

Max./Min. code length: Each symbol has own max./Min. code length. If both setting of max./Min. code length are "00"s, the setting of global max./Min. code length is effective. The length is defined as to the actual barcode data length to be sent. Label with length exceeds these limits will be rejected. Make sure that the minimum length setting is no greater than the maximum length setting, or otherwise all the labels of the symbol will not be readable. In particular, you can see the same value for both minimum and maximum reading length to force the fixed length barcode decoded.

Code ID setting: Refer to

Code ID setting

 of [7-5 UPC-A](#).

Insertion group selection: Refer to

Insertion group selection

 of [7-5 UPC-A](#).

Start/End transmission: The start and end characters of Code 39 are "*"s. You can transmit all data digits including two "*"s.

**** as data character:** By setting Enable, "*" can be recognized as data character.

Convert Code 39 to Code 32: Code 32 is a variant of Code 39 used by the Italian pharmaceutical industry. Note that Code 39 must be enabled in order for this parameter to function.

Format of Code 32

"A" (optional)	Data digits (8 digits)	Check digit
----------------	------------------------	-------------

















Code 32 Prefix "A" transmission: By setting Enable, the prefix character "A" can be added to all Code 32 barcodes.









Trioptic Code 39 read: Trioptic Code 39 is a variant of Code 39 used in the marking of magnetic tapes and computer cartridges. Trioptic Code 39 symbols always contain six characters.

Format

Start character (\$)	Data digits (6 digits)	End character (\$)
----------------------	------------------------	--------------------

Trioptic Code 39 Start/End transmission: The start and end characters of Trioptic Code 39 are "\$"s. You can transmit all data digits including two "\$"s.

Items	Single-scan setting
Read	 %1501D00% Disable
	 %1501D01% * Enable
Check digit verification	 %1502D00% * Disable
	 %1502D01% Enable
Check digit transmission	 %1503D00% * Disable
	 %1503D01% Enable
Max. code length 00-99	 %1504D99% * 99
Min. code length 00-99	 %1505D01% * 01
Code ID setting 00-FF ₁₆ (ASCII)	 %1506H4D% * <M>
Insert group selection 00-44	 %1507D00% * None
Format	 %1508D00% * Standard
	 %1508D01% Full ASCII
Start/End transmission	 %1509D00% * Disable
	 %1509D01% Enable
“*” as data character	 %1510D00% * Disable
	 %1510D01%

Items	Single-scan setting
	Enable
Convert Code 39 to Code 32	 %1511D00% *
	Disable  %1511D01%
Code 32 Prefix "A" transmission	 %1512D00% *
	Disable  %1512D01% Enable
Trioptic Code 39 read	 %1513D00% *
	Disable  %1513D01% Enable
Trioptic Code 39 Start/End transmission	 %1514D00% *
	Disable  %1514D01% Enable

7-11 Interleaved 2 of 5

Read:

Format

Data digits (Variable)	Check digit (optional)
------------------------	------------------------

Check digit verification: The check digit is made as the sum module 10 of the numerical values of all data digits. There are two optional check digit algorithms: the specified Uniform Symbol Specification (USS) and the Optical Product Code Council (OPCC).

Check digit transmission: By setting Enable, check digit will be transmitted.

Max./Min. code length: Refer to Max./Min. code length of [7-10 Code 39](#).

Code ID setting: Refer to Code ID setting of [7-5 UPC-A](#).

Insertion group selection: Refer to Insertion group selection of [7-5 UPC-A](#).

Items	Single-scan setting
Read	 %1601D00% Disable
	 %1601D01% * Enable
Check digit verification	 %1602D00% * Disable
	 %1602D01% USS
Check digit transmission	 %1603D00% * Disable
	 %1603D01% Enable
Max. code length 00-99	 %1604D99% * 99
Min. code length 00-99	 %1605D06% * 06
Code ID setting 00-FF ₁₆ (ASCII)	 %1606H49% * < >
Insert group selection 00-44	 %1607D00% * None

7-12 Industrial 2 of 5 (Discrete 2 of 5)

Read:

Format

Data digits (variable)

Max./Min. code length: Refer to Max./Min. code length of [7-10 Code 39](#).

Code ID setting: Refer to Code ID setting of [7-5 UPC-A](#).

Insertion group selection: Refer to Insertion group selection of [7-5 UPC-A](#).

Items	Single-scan setting
Read	 %1701D00% * Disable
	 %1701D01% * Enable
Max. code length 00-99	 %1702D99% * 99
Min. code length 00-99	 %1703D04% * 04
Code ID setting 00-FF ₁₆ (ASCII)	 %1704H48% * <H>
Insert group selection 00-44	 %1705D00% * None

7-13 Matrix 2 of 5

Read:

Format

Data digits (variable)	Check digit (optional)
------------------------	------------------------

Max./Min. code length: Refer to Max./Min. code length of [7-10 Code 39](#).

Code ID setting: Refer to Code ID setting of [7-5 UPC-A](#).

Insertion group selection: Refer to Insertion group selection of [7-5 UPC-A](#).

Items	Single-scan setting
Read	 %1801D00% Disable
	 %1801D01% * Enable
Max. code length 00-99	 %1804D99% * 99
Min. code length 00-99	 %1805D06% * 06
Code ID setting 00-FF ₁₆ (ASCII)	 %1806H58% * <X>
Insert group selection 00-44	 %1807D00% * None

7-14 Codabar

Read:

Format

Start character	Data digits (variable)	Check digit (optional)	End character
-----------------	------------------------	------------------------	---------------

Max./Min. code length: Refer to [Max./Min. code length](#) of [7-10 Code 39](#).













Code ID setting: Refer to [Code ID setting](#) of [7-5 UPC-A](#).

Insertion group selection: Refer to [Insertion group selection](#) of [7-5 UPC-A](#).

Start/End type: Codabar has four pairs of Start/End pattern; you may select one pair to match your application.

Start/End transmission: Refer to [Start/End transmission](#) of [7-10 Code 39](#).

Start/End character equality: By setting Enable, the start and end character of a Codabar barcode must be the same.

Items	Single-scan setting
Read	 %1901D00% Disable
	 %1901D01% * Enable
Max. code length 00-99	 %1904D99% * 99
Min. code length 00-99	 %1905D04% * 04
Code ID setting 00-FF ₁₆ (ASCII)	 %1906H4E% * <N>
Insert group selection 00-44	 %1907D00% * None
Start/End type	 %1908D00% * ABCD/ABCD
	 %1908D01% abcd/abcd
	 %1908D02% ABCD/TN*E
	 %1908D03% abcd/tn*e
Start/End transmission	 %1909D00% * Disable
	 %1909D01% Enable

7-15 Code 128

Read:

Format









Data digits (variable)	Check digit (optional)
------------------------	------------------------

Max./Min. code length: Refer to Max./Min. code length of [7-10 Code 39](#).

Code ID setting: Refer to Code ID setting of [7-5 UPC-A](#).

Insertion group selection: Refer to Insertion group selection of [7-5 UPC-A](#).

Truncate leading zeros: The leading “0” digits of Code 128 barcode characters can be truncated when the feature is enabled.

Items	Single-scan setting
Read	 %2001D00% Disable
	 %2001D01% * Enable
Max. code length 00-99	 %2004D99% * 99
Min. code length 00-99	 %2005D01% * 01
Code ID setting 00-FF ₁₆ (ASCII)	 %2006H4B% * <K>
Insert group selection 00-44	 %2007D00% * None
Truncate leading zeros	 %2008D00% * Disable
	 %2008D01% All leading “0”
	 %2008D02% Only the first “0”

7-16 UCC/EAN 128

Read:

Format

Data digits (variable)	Check digit (optional)
------------------------	------------------------

Max. /Min. code length: Refer to Max./Min. code length of [7-10 Code 39](#).

Code ID setting: Refer to Code ID setting of [7-5 UPC-A](#).

Insertion group selection: Refer to Insertion group selection of [7-5 UPC-A](#).

Truncate leading zeros: Refer to Truncate leading zeros of [7-15 Code 128](#).

Items	Single-scan setting
Read	 %2501D00% Disable
	 %2501D01% * Enable
Max. code length 00-99	 %2504D99% * 99
Min. code length 00-99	 %2505D01% * 01
Code ID setting 00-FF ₁₆ (ASCII)	 %2506H4B% * <K>
Insert group selection 00-44	 %2507D00% * None
Truncate leading zeros	 %2508D00% * Disable
	 %2508D01% All leading "0"
	 %2508D02% Only the first "0"

7-17 ISBT 128

Read:

Format

Start character (“=” or “&”)	Data digits (variable)	Check digit (optional)
------------------------------	------------------------	------------------------

Max./Min. code length: Refer to Max./Min. code length of [7-10 Code 39](#).

Code ID setting: Refer to Code ID setting of [7-5 UPC-A](#).

Insertion group selection: Refer to Insertion group selection of [7-5 UPC-A](#).

Items	Single-scan setting
Read	 %3301D00% Disable
	 %3301D01% * Enable
Max. code length 00-99	 %3304D99% * 99
Min. code length 00-99	 %3305D01% * 01
Code ID setting 00-FF ₁₆ (ASCII)	 %3306H4B% * <K>
Insert group selection 00-44	 %3307D00% * None

7-18 Code 93

Read:

Format

Data digits (variable)	2 check digits (optional)
------------------------	---------------------------

Max./Min. code length: Refer to Max./Min. code length of [7-10 Code 39](#).

Code ID setting: Refer to Code ID setting of [7-5 UPC-A](#).

Insertion group selection: Refer to Insertion group selection of [7-5 UPC-A](#).

Items	Single-scan setting
Read	 %2101D00% Disable
	 %2101D01% * Enable
Max. code length 00-99	 %2104D99% * 99
Min. code length 00-99	 %2105D01% * 01
Code ID setting 00-FF ₁₆ (ASCII)	 %2106H4C% * <L>
Insert group selection 00-44	 %2107D00% * None

7-19 Code 11

Read:

Format

Data digits (variable)	Check digit 1 (optional)	Check digit 2 (optional)
------------------------	---------------------------	--------------------------

Check digit verification: The check digit is presented as the sum module 11 of all data digits.

Check digit transmission: By setting Enable, check digit 1 and check digit 2 will be transmitted upon your selected check digit verification method.

Max./Min. code length: Refer to

Max./Min. code length

 of [7-10 Code 39](#).

Code ID setting: Refer to











Code ID setting

 of [7-5 UPC-A](#).

Insertion group selection: Refer to

Insertion group selection

 of [7-5 UPC-A](#).

Items	Single-scan setting
Read	 %2201D00% * Disable
	 %2201D01% Enable
Check digit verification	 %2202D00% None
	 %2202D01% * One digit
	 %2202D02% Two digits
Check digit transmission	 %2203D00% * Disable
	 %2203D01% Enable
Max. code length 00-99	 %2204D99% * 99
Min. code length 00-99	 %2205D04% * 04
Code ID setting 00-FF ₁₆ (ASCII)	 %2206H56% * <V>
Insert group selection 00-44	 %2207D00% * None

7-20 MSI/Plessey

Read:

Format

Data digits (variable)	Check digit 1 (optional)	Check digit 2 (optional)
------------------------	--------------------------	--------------------------

Check digit verification: The MSI/Plessey has one or two optional check digits. There are three methods of verifying check digits, i.e. Mod 10, Mod 10/10 and Mod 10/11. The check digit 1 and check digit 2 will be calculated as the sum module 10 or 11 of the data digits.

Check digit transmission: By setting Enable, check digit 1 and check digit 2 will be transmitted upon your selected check digit verification method.

Max./Min. code length: Refer to

Max./Min. code length

 of [7-10 Code 39](#).

Code ID setting: Refer to













Code ID setting

 of [7-5 UPC-A](#).

Insertion group selection: Refer to

Insertion group selection

 of [7-5 UPC-A](#).

Items	Single-scan setting
Read	 %2301D00% * Disable
	 %2301D01% * Enable
Check digit verification	 %2302D00% * Disable
	 %2302D01% * 1 digit (Mod 10)
	 %2302D02% * 2 digits (Mod 10/10)
	 %2302D03% * 2 digits (Mod 10/11)
Check digit transmission	 %2303D00% * Disable
	 %2303D01% * Enable
Max. code length 00-99	 %2304D99% * 99
Min. code length 00-99	 %2305D04% * 04
Code ID setting 00-FF ₁₆ (ASCII)	 %2306H4F% * <O>
Insert group selection 00-44	 %2307D00% * None

7-21 UK/Plessey

Read:

Format

Data digits (variable)	2 check digits (optional)
------------------------	---------------------------

Check digit transmission: By setting Enable, check digit will be transmitted.

Max./Min. code length: Refer to [Max./Min. code length](#) of [7-10 Code 39](#).

Code ID setting: Refer to [Code ID setting](#) of [7-5 UPC-A](#).

Insertion group selection: Refer to [Insertion group selection](#) of [7-5 UPC-A](#).

Items	Single-scan setting
Read	 %2401D00% Disable
	 %2401D01% * Enable
Max. code length 00-99	 %2404D99% * 99
Min. code length 00-99	 %2405D01% * 01
Code ID setting 00-FF ₁₆ (ASCII)	 %2406H55% * <U>
Insert group selection 00-44	 %2407D00% * None

7-22 China Post

Read:

Format

11 Data digits

Max. /Min. code length: Refer to **Max./Min. code length** of *7-10 Code 39*. The code length of China Post is 11.

Code ID setting: Refer to **Code ID setting** of *7-5 UPC-A*.

Insertion group selection: Refer to **Insertion group selection** of *7-5 UPC-A*.

Items	Single-scan setting
Read	 %2601D00% Disable
	 %2601D01% * Enable
Max. code length 00-99	 %2604D11% * 11
Min. code length 00-99	 %2605D11% * 11
Code ID setting 00-FF ₁₆ (ASCII)	 %2606H54% * <T>
Insert group selection 00-44	 %2607D00% * None

7-23 GS1 DataBar (GS1 DataBar Truncated)

GS1 DataBar Truncated is structured and encoded the same as the standard GS1 DataBar format, except its height is reduced to a 13 modules minimum; while GS1 DataBar should have a height greater than or equal to 33 modules.

Read:

Format

16 Data digits

Code ID setting: Refer to Code ID setting of [7-5 UPC-A](#).

Insertion group selection: Refer to Insertion group selection of [7-5 UPC-A](#).

Conversion:

UCC/EAN 128- Refer to Code ID transmission of [7-35 String transmission](#),]Cm will be identified as AIM ID.

UPC-A or EAN-13- Barcode beginning with a single zero as the first digit has the leading “010” stripped and the barcode reported as EAN-13. Barcode beginning with two or more zeros but not six zeros has the leading “0100” stripped and the barcode reported as UPC-A.

Items	Single-scan setting
Read	 %2701D00% Disable
	 %2701D01% * Enable
Code ID setting 00-FF ₁₆ (ASCII)	 %2702H52% * <R>
Insert group selection 00-44	 %2703D00% * None
Conversion	 %2704D00% * None
	 %2704D01% UCC/EAN 128
	 %2704D02% UPC-A or EAN-13

7-24 GS1 DataBar Limited

Read:

Format

16 Data digits

Code ID setting: Refer to [Code ID setting](#) of [7-5 UPC-A](#).

Insertion group selection: Refer to [Insertion group selection](#) of [7-5 UPC-A](#).

Conversion: Refer to [Conversion](#) of [7-23 GS1 DataBar \(GS1 DataBar Truncated\)](#).

Items	Single-scan setting
Read	 %2801D00% Disable
	 %2801D01% * Enable
Code ID setting 00-FF ₁₆ (ASCII)	 %2802H52% * <R>
Insert group selection 00-44	 %2803D00% * None
Conversion	 %2804D00% * None
	 %2804D01% UCC/EAN 128
	 %2804D02% UPC-A or EAN-13

7-25 GS1 DataBar Expanded

Read:

Format

Data characters (variable)

Code ID setting: Refer to Code ID setting of [7-5 UPC-A](#).



Insertion group selection: Refer to Insertion group selection of [7-5 UPC-A](#).

Conversion:



UCC/EAN 128- Refer to Code ID transmission of [7-35 String transmission](#),]Cm will be identified as AIM ID.

Items	Single-scan setting
Read	 %2901D00% Disable
	 %2901D01% * Enable
Max. code length 00-99	 %2902D99% * 99
Min. code length 00-99	 %2903D01% * 01
Code ID setting 00-FF ₁₆ (ASCII)	 %2904H52% * <R>
Insert group selection 00-44	 %2905D00% * None
Conversion	 %2906D00% * None
	 %2906D01% UCC/EAN 128



7-26 PDF417

Items	Single-scan setting
Read	 %3001D00% Disable
	 %3001D01% * Enable



7-27 MicroPDF417

Items	Single-scan setting
Read	 %3101D00% * Disable
	 %3101D01% Enable



7-28 QR Code

Items	Single-scan setting
Read	 %4001D00% Disable
	 %4001D01% * Enable



7-29 MicroQR Code

Items	Single-scan setting
Read	 %4501D00% * Disable
	 %4501D01% Enable



7-30 Data Matrix

Items	Single-scan setting
Read	 %4101D00% Disable
	 %4101D01% * Enable

7-31 Han Xin Code

Items	Single-scan setting
Read	 %4201D00% * Disable
	 %4201D01% Enable

7-32 Aztec Code

Items	Single-scan setting
Read	 %4301D00% * Disable
	 %4301D01% Enable

7-33 G1-G4 & C1-C3 & FN1 substitution string setting

Format of barcode data transmission:

Prefix	Code name	Preamble	Code ID	Code length	Code data	Code ID	Postamble	Suffix
--------	-----------	----------	---------	-------------	-----------	---------	-----------	--------

Suffix string setting: The <enter> key is represented in different ASCII when it is applied by different OS. For a Windows/DOS OS, <enter> is represented as <CR><LF> (0x0D 0x0A); for an Apple MAC OS, <enter> is represented as <CR> (0x0D); for a Linux/Unix OS, <enter> is represented as <LF> (0x0A).

Prefix/Suffix/Preamble/Postamble string setting:

They are appended to the data automatically when a barcode is decoded.

Example: Add a symbol of "\$" as a prefix for all symbols.

Steps:

- 1) Scan the option barcode of Prefix string setting.
- 2) Use the ASCII table to find the value of \$→24.
- 3) Scan 2 and 4 from the barcode on the last page.
- 4) Scan END barcode.

Scanning steps: Scan the following barcodes in order.



Insert G1/G2/G3/G4 string setting: The terminal offers 4 positions and 4 character strings to insert among the symbol.

Example: Set G1 string to be "AB".

Original code data	"1 2 3 4 5 6"
Output code data	"1 2 A B 3 4 5 6"

Steps:

- 1) Scan the option barcode of Insert G1 string setting.
- 2) Use the ASCII table to find the value of A→41, B→42.
- 3) Scan 4, 1 and 4, 2 from the barcode on the last page.
- 4) Scan END barcode.
- 5) Refer to [7-34 G1-G4 string position & Code ID position](#).
- 6) Refer to [7-4 Scanning mode and some global settings](#).

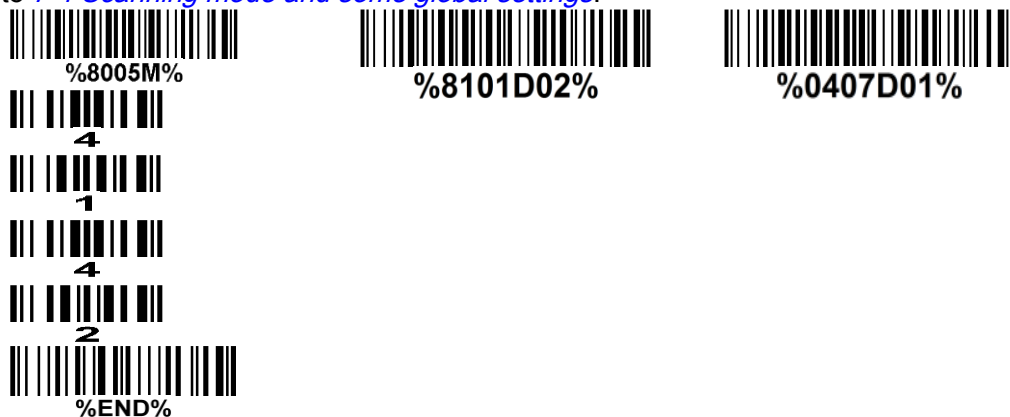

Testing barcode:



FN1 substitution string setting: The FN1 character (0x1D) in an UCC/EAN128 barcode, or a Code 128 barcode, or a GS1 DataBar barcode can be substituted with a defined string.

Single character C1/C2 replacement: By setting, a defined character in the data string can be replaced by another defined character. The C1 and C2 replacement can be applied simultaneously.

Example: Replace all the “A” character in a data string with “B” character.

Original code data	“1 2 3 A 5 A”
Output code data	“1 2 3 B 5 B”

Steps: scan the following barcodes in order. The ASCII value for “A” is 41, and the ASCII value for “B” is 42.

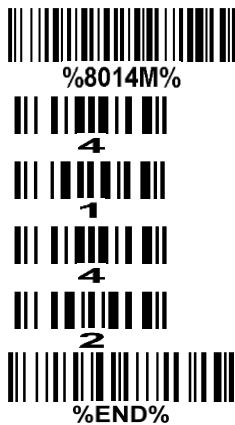

Test barcode:



Multiple characters C3 replacement: By setting, a number of defined characters in the data string can be replaced by other defined characters. The maximum number of characters to replace is 11.

Example: Replace all the “A” character in a data string with “B” character; replace “C” with “D”; replace “E” with “F”.

Original code data	“1 2 3 A 4 C 5 6 E 7 8”
Output code data	“1 2 3 B 4 D 5 6 F 7 8”

Steps: scan the following barcodes in order. The ASCII value for “A” is 41, for “B” is 42, for “C” is 43, for “D” is “44”, for “E” is 45, and for “F” is 46.

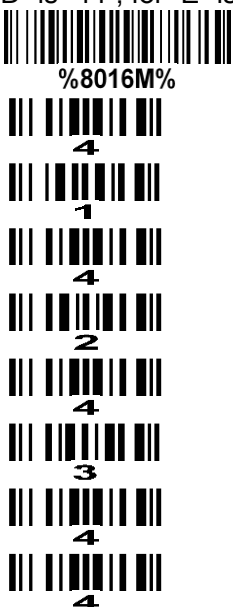

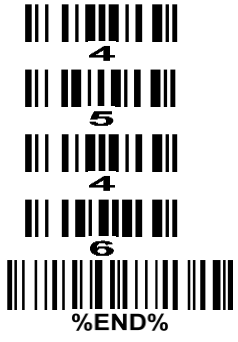



Test barcode:



Multiple-scan setting			Single-scan setting
Option barcode	Option	Alpha. Entry	
Prefix string setting  %8001M%	0-22 characters	00-FF ₁₆	
	None	00*	 %8001H00% *
Suffix string setting  %8002M%	0-22 characters	00-FF ₁₆	
	<ENTER>	0D0A*	
Preamble string setting  %8003M%	0-22 characters	00-FF ₁₆	
	None	00*	 %8003H00% *
Postamble string setting  %8004M%	0-22 characters	00-FF ₁₆	
	None	00*	 %8004H00% *
Insert G1 string setting  %8005M%	0-22 characters	00-FF ₁₆	
	None	00*	 %8005H00% *
Insert G2 string setting  %8006M%	0-22 characters	00-FF ₁₆	
	None	00*	 %8006H00% *
Insert G3 string setting  %8007M%	0-22 characters	00-FF ₁₆	
	None	00*	 %8007H00% *
Insert G4 string setting  %8008M%	0-22 characters	00-FF ₁₆	
	None	00*	 %8008H00% *
FN1 substitution string setting  %8009M%	0-4 characters	00-FF ₁₆	
	<SP>	20*	 %8009H20% *
Single character C1 replacement  %8014M%		0000-FFFF ₁₆	
	<0000>	0000*	
Single character C2		0000-FFFF ₁₆	

Multiple-scan setting			Single-scan setting
Option barcode	Option	Alpha. Entry	
replacement  %8015M%	<0000>	0000*	
Multiple characters C3 replacement  %8016M%		0000-FFFF ₁₆	
	<0000>	0000*	
 %END%			





7-34 G1-G4 string position & Code ID position

Format of barcode data transmission:

Prefix	Code name	Preamble	Code ID	Code length	Code data	Code ID	Postamble	Suffix
--------	-----------	----------	---------	-------------	-----------	---------	-----------	--------

Insert G1/G2/G3/G4 string position: The terminal offers 4 positions to insert strings among the symbol. In case of the insertion position is greater than the length of the symbol, the insertion of string is not effective.

Code ID position: It is allowed to select different positions of code ID placement.

Items	Single-scan setting
Insert G1 string position 00-99	 %8101D00% * 00
Insert G2 string position 00-99	 %8102D00% * 00
Insert G3 string position 00-99	 %8103D00% * 00
Insert G4 string position 00-99	 %8104D00% * 00
Code ID position	 %8105D00% * Before code data
	 %8105D01% After code data

7-35 String transmission

Note: The information in this chapter is closely related to 7-33 G1-G6 & C1-C3 & FN1 substitution string setting.

Format of barcode data transmission:

Prefix	Code name	Preamble	Code ID	Code length	Code data	Code ID	Postamble	Suffix
--------	-----------	----------	---------	-------------	-----------	---------	-----------	--------

Prefix transmission: By setting Enable, prefix will be appended before the data transmitted.

Suffix transmission: By setting Enable, suffix will be appended after the data is transmitted.

Code name transmission: By setting Enable, code name will be transmitted before code data.

Preamble transmission: By setting Enable, preamble will be appended before the data transmitted.

Postamble transmission: By setting Enable, postamble will be appended after the data is transmitted.

Code ID transmission: Code ID can be transmitted in the format of either Proprietary ID or AIM ID.

Refer to [1-2 Default setting for each barcode](#).

Code length transmission: The length of code data string can be transmitted before the code data when Enable is selected. The length is represented by a number with two digits.











Case conversion: The characters within code data or the whole output string can be set in either upper case or lower case.

FN1 substitution transmission: The terminal supports a FN1 substitution feature. The replacement string of FN1 can be chosen by user (see [7-33 G1-G4 & C1-C3 & FN1 substitution string setting](#)).

Transmit the first N data characters only: The terminal supports to only transmit the first N data characters of a barcode. The number of N can be set as a digit between 1 and 99.

Transmit the last N data characters only: The terminal supports to only transmit the last N data characters of a barcode. The number of N can be set as a digit between 1 and 99.

Items	Single-scan setting
Prefix transmission  %8201M%	 %8201D00% * Disable
	 %8201D01% Enable
Suffix transmission  %8202M%	 %8202D00% Disable
	 %8202D01% * Enable
Code name transmission  %8203M%	 %8203D00% * Disable
	 %8203D01% Enable
Preamble transmission  %8204M%	 %8204D00% * Disable
	 %8204D01% Enable
Postamble transmission  %8205M%	 %8205D00% * Disable
	 %8205D01% Enable
Code ID transmission  %8206M%	 %8206D00% * Disable
	 %8206D01% Proprietary ID
	 %8206D02% AIM ID
Code length transmission  %8207M%	 %8207D00% * Disable
	 %8207D01%

Items	Single-scan setting
	Enable
<p data-bbox="432 510 644 539">Case conversion</p>  <p data-bbox="480 607 600 636">%8208M%</p>	 <p data-bbox="1007 309 1133 338">%8208D00% *</p> <p data-bbox="1023 353 1117 383">Disable</p>
	 <p data-bbox="1007 441 1133 470">%8208D01%</p> <p data-bbox="963 477 1176 506">Upper (data only)</p>
	 <p data-bbox="1007 562 1133 591">%8208D02%</p> <p data-bbox="963 598 1176 627">Lower (data only)</p>
	 <p data-bbox="1007 687 1133 716">%8208D03%</p> <p data-bbox="948 723 1195 752">Upper (whole string)</p>
	 <p data-bbox="1007 804 1133 833">%8208D04%</p> <p data-bbox="948 840 1195 869">Lower (whole string)</p>
<p data-bbox="352 943 724 972">FN1 substitution transmission</p>  <p data-bbox="480 1039 600 1068">%8209M%</p>	 <p data-bbox="1007 920 1133 949">%8209D00% *</p> <p data-bbox="1023 965 1117 994">Disable</p>
	 <p data-bbox="1007 1052 1133 1081">%8209D01%</p> <p data-bbox="1023 1088 1117 1117">Enable</p>
<p data-bbox="288 1167 788 1196">Transmit the first N data characters only</p> <p data-bbox="501 1216 576 1245">01-99</p>	 <p data-bbox="995 1180 1142 1209">%8211D99% *</p> <p data-bbox="1027 1229 1110 1258">99 (All)</p>
<p data-bbox="288 1328 788 1357">Transmit the last N data characters only</p> <p data-bbox="501 1377 576 1406">01-99</p>	 <p data-bbox="995 1350 1142 1379">%8212D99% *</p> <p data-bbox="1027 1400 1110 1429">99 (All)</p>

8 Barcode representing non-printable character

Notes to make the following barcode:

1. According to different barcode printing software, the method of printing following barcode is different.
2. If using CODESOFT software, firstly read the information through "Help→Index→Code128→Special input syntax".

Also refer to ASCII table. For example, if we wish to make "F1" barcode, select "Code128", then select "CODE A" type, and input "{DC1}" as data.



Up ↑



Down ↓



Left ←



Right →



Page Up



Page Down



Backspace



Tab



Home



End



Enter



Insert



Delete



F1



F2



F3



F4



F5



F6



F7



F8



F9



F10



Esc



F11



F12

9 ASCII Table

		for keyboard wedge		for RS-232	
		0	1	0	1
L \ H	0	Null		NUL	DLE
	1	Up	F1	SOH	DC1
	2	Down	F2	STX	DC2
	3	Left	F3	ETX	DC3
	4	Right	F4	EOT	DC4
	5	PgUp	F5	ENQ	NAK
	6	PgDn	F6	ACK	SYN
	7		F7	BEL	ETB
	8	Bs	F8	BS	CAN
	9	Tab	F9	HT	EM
	A		F10	LF	SUB
	B	Home	Esc	VT	ESC
	C	End	F11	FF	FS
	D	Enter	F12	CR	GS
	E	Insert	Ctrl+	SO	RS
	F	Delete	Alt+	SI	US

Notes: The 2nd and the 3rd columns above are used for keyboard wedge only.

L \ H	2	3	4	5	6	7
	0	SP	0	@	P	`
1	!	1	A	Q	a	q
2	"	2	B	R	b	r
3	#	3	C	S	c	s
4	\$	4	D	T	d	t
5	%	5	E	U	e	u
6	&	6	F	V	f	v
7	'	7	G	W	g	w
8	(8	H	X	h	x
9)	9	I	Y	i	y
A	*	:	J	Z	j	z
B	+	;	K	[k	{
C	,	<	L	\	l	
D	-	=	M]	m	}
E	.	>	N	^	n	~
F	/	?	O	_	o	DEL

Example: ASCII "A" = "41".

10 Test Chart

UPC-A



UPC-E



UPC-E1

(Default setting: Disable)



EAN-13



ISBN/ISSN



EAN-8



Code 39



Code 32



Trioptic Code 39

(Default setting: Disable)



Interleaved 2 of 5



Industrial 2 of 5

(Default setting: Disable)



Matrix 2 of 5



Codabar



Code 128



01AZ[+*/]za98

UCC/EAN 128



01AZ[]+az54

ISBT 128



=1234 56789

Code 93



01AZ+/*az89

Code 11

(Default setting: Disable)



123456789-0

MSI/Plessey

(Default setting: Disable)



0123456789

UK/Plessey



01ABEF89

China Post



54789632145

GS1 DataBar (GS1 DataBar Truncated)



(01) 12345678901231

GS1 DataBar Limited



(01) 1 2345678 90126 2

GS1 DataBar Expanded



Ab_09+yZ

PDF417



12=890ab-+%xyz

MicroPDF417

(Default setting: Disable)



12345678abcABCMicroPDF417

QR code



1234567890ABCD-+()&*% ^@# \$!XYZ

MicroQR Code

(Default setting: Disable)



0123456789MicroQR

Data Matrix



123890abc-+=&*% ^!mndo

Aztec Code

(Default setting: Disable)



12345678901234567890

Han Xin Code

(Default setting: Disable)



1234567890Hanxin

11 Return default parameters & firmware version



%%%DEF

WARNING: Restore Factory Defaults

Scan this barcode to restore the factory default values.



%%SVER

Firmware Version List

Scan this barcode to display the firmware version.

12 Configuration alphanumeric entry barcode



To finish parameter setting, please scan the bar code below.

